



Construction Soil and Water Management Plan

N228

Moore Park Precinct Village and Carpark

25 March 2026

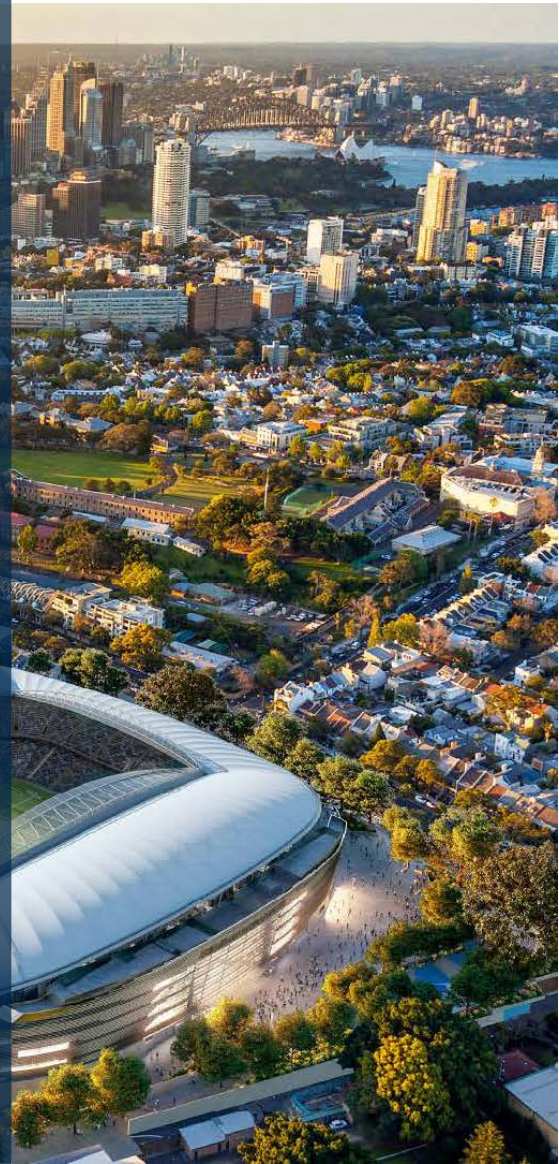

Project overview

Project Site Address: Driver Ave Moore Park NSW 2021	BESIX Watpac State Division Address: Level 15, 210 George Street SYDNEY NSW 2000
Project Commencement Date: 4 March 2024	BESIX Watpac ABN: 71 010 462 816

Document Control

Client:	VenuesNSW
Title:	Construction Soil and Water Management Plan
Subtitle:	Moore Park Precinct Village and Carpark
Owner / Approver:	Project Manager
TB Document Reference:	PVC-WTP-04-RP-EN00XX02
TB Revision:	05

Revision history

Version	Date	Revision Description	Release Sign off
00	16/02/2024	Draft Plan for review, developed for CC1 requirements	Nicholas Papanikolaou
01	09/04/24	Updated to address Savills comments made on CEMP	Nicholas Papanikolaou
02	07/05/24	Updated to address Savills comments received on 05/05/24	Nicholas Papanikolaou
03	24/06/2024	Updated as per DPHI comments	Nicholas Papanikolaou
04	22/04/2025	Updated as per SSD Compliance and Revised MOD	Nicholas Papanikolaou
05	25/03/2025	Six Monthly Review	Amr Mohamed

BESIX Watpac Approvals

Name	Role & Title	Signature	Date
Nicholas Papanikolaou	Reviewer/ Project Manager	 Nicholas Papanikolaou	22/04/2025
Amr Mohamed	Project Manager		25/03/2025

Note: A controlled copy of the Soil and Water Management Procedure will be distributed to the VenuesNSW Principal's Representative, Independent Certifier (IC) and other nominated stakeholders, and it will be made available to all BESIX Watpac employees and subcontractors in soft copy format through the project document control system.

This procedure, when printed, will be uncontrolled and it will be the responsibility of each user to confirm the currency of the plan through the project document control system.

Contents

Construction Soil and Water Management Plan

1	Compliance Matrix	iii
2	Document Purpose & Development	v
3	Project Overview	v
4	Potential Impacts	vi
5	Soil and Water Management Objectives	vii
6	Roles and Responsibilities	viii
6.1	Key BESIX Watpac Personnel	viii
6.2	Specialist Consultants	viii
6.2.1	Contamination & Acid Sulphate Soils Expert	viii
6.2.2	Water Quality Monitoring	ix
7	Soil Management	ix
7.1	Contamination and Acid Sulfate Soils	ix
7.2	Waste Classification and disposal	x
7.3	Unexpected Contamination	x
7.4	Erosion & Runoff	x
7.5	Soil Monitoring	xi
7.6	Material Importation	xi
8	Soil and Water Quality Action Planning	xii
9	Environmental Planning & Flooding	xxiii
10	Spill Response Management	xxiv
9.1	Spill Mitigation Measures	xxiv
9.2	Storage and Handling – Hazardous Chemicals	xxiv

11 Record Management	xxv
Appendix A – Discharge Permit	xxvi
Appendix B – Erosion and Sediment Control Plan	xxix
Appendix C – Water Quality Management Manual	xxx
Appendix D – Curriculum Vitae of Suitably Qualified Expert (as per Condition B25a)	xxxi

1 Compliance Matrix

The following compliance matrix demonstrates the alignment of the BESIX Watpac Construction Soil and Water Management Plan (CSWMSP) with conditions B25, C27, C28, C33, C40 and C44 (Table 1) of the SSD 9835, approved on 6 December 2019 and modified thereafter. The City of Sydney Council was sent the CSWMSP for review on 08/05/24, no comments have been received to date (24/06/24).

Table 1 Compliance Matrix

Construction Environmental Management Plan Requirements		Reference
B25	The Applicant must prepare a Construction Soil and Water Management Plan (CSWMSP) and the plan must address, but not be limited to, the following:	This Plan
a)	be prepared by a suitably qualified expert, in consultation with Council;	This Plan
b)	describe the details of all erosion and sediment controls to be implemented during construction;	Section 8
c)	provide a plan of how all construction works will be managed in a wet-weather events (i.e., storage of equipment, stabilisation of the Site)	Section 8
d)	provide a summary of any ground investigations completed to date;	Section 6.1
e)	detail all off-Site stormwater flows from the Site and methods to ensure that sediment is not mobilised in stormwater flows leaving the site; and	Section 8
f)	describe the measures that must be implemented to manage stormwater and flood flows for small and large sized events, including, but not limited to 1 in 1-year ARI, 1 in 5-year ARI and 1 in 100-year ARI.	Section 8
g)	detail the proposed stormwater disposal and drainage from the development, designed in accordance with:	Section 8 Note: Diversion of key stormwater infrastructure was approved as part of a modification to Stage 1 consent (SSDA-9249) on 5 August 2019. Works have been undertaken by the Stage 1 contractor.
i)	Australian Rainfall and Runoff – A Guide to Flood Estimation, Volumes 1 and 2 (1987);	Section 8
ii)	SA/NZS 3500.3.2 National Plumbing and Drainage Part 3.2: Stormwater Drainage – Acceptable Solutions; and	Section 8
iii)	Managing Urban Stormwater – Soils and Construction Volume 1 (4th Edition March 2004) – NSW Department of Housing.	Section 8

h)	details demonstrating that fine particulates from construction works would not be entrained in stormwater runoff and adversely impact on Kippax Lake, the underlying groundwater resources and other downstream properties;	Section 8
i)	monitoring techniques to ensure that the quality of water within the detention / settling ponds comply with the applicable standards within the Managing Urban Stormwater – Soils and Construction Volume 1 (4th Edition March 2004);	Section 8
j)	methods for testing of the water quality (suspended solids, turbidity and contaminants) prior to discharging from the site into the stormwater infrastructure on Driver Avenue, to ensure compliance with the applicable standards within the Managing Urban Stormwater – Soils and Construction Volume 1 (4th Edition March 2004); and	Appendix A
k)	methods of evaluating the water quality testing results by a suitably qualified water quality expert.	Appendix A
C27	All erosion and sediment control measures must be effectively implemented and maintained at or above design capacity for the duration of the construction in accordance with the CSWMSP.	Section 8
C28	The Applicant must: <ul style="list-style-type: none"> (a) ensure that only VENM, ENM, or other material approved in writing by EPA is brought onto the site; (b) ensure that imported topsoil for the playing field inside the stadium meets the Recreational / Recreational Open Space criteria defined in Schedule B1 of the National Environment Protection Measure, As Amended (NEPC, 2013); (c) keep accurate records of the volume and type of material to be used; and (d) make these records available to the Department and the Certifying Authority upon request. 	Section 8
C33	If unexpected contamination is found during site works at levels that may pose a risk to human health or environment, the unexpected finds protocol in accordance with the CEMP (condition B22) must be implemented on site and the Site Auditor must inform the EPA and the Planning Secretary immediately.	Section 8
C40	The Applicant must ensure that concrete waste and rinse water are not disposed of on the site and are prevented from entering any natural or artificial watercourse or waterbody.	Section 8
C44	In the event that groundwater is intercepted during construction works and dewatering is required, written approval and relevant licences must be obtained from the relevant authorities (such as the Water Group within the Department or Council's Public Domain Unit for any discharge of groundwater into Council's stormwater system).	Section 8

2 Document Purpose & Development

The purpose of the soil and water management procedure is to minimise potential adverse soil and water environmental impacts occurring during BESIX Watpac's construction activities. The document has been developed by BESIX Watpac professionals, in consultation with ESCP professional Andrew Littlewood, curriculum vitae attached as Appendix D.

3 Project Overview

Stage 2 of the Sydney Football Stadium (SFS) Redevelopment (SSD 9835) was approved by the Minister for Planning and Public Spaces on 6 December 2019. SSD 9835 has been modified on eight previous occasions as summarised in Table 2.

Table 2 Modifications to SSD 9835

Modification	Approved	Description
Modification 1	3 April 2020	Amend Conditions B14 and B15 to enable the condition to be satisfied in accordance with the principles and framework prescribed by the Contaminated Land Management Act 1997.
Modification 2	14 December 2020	Reinstate fitness facilities that were previously available within the former SFS.
Modification 3	7 December 2020	Alter the approved mezzanine slabs at the eastern and western stands and relocate the approved administration facilities. Design amendments to the southwestern glazed façade. Inclusion of an additional stadium signage condition.
Modification 4	22 April 2021	Relocate the photovoltaic (PV) cells from the stadium's roof to Level 5 (above the eastern and western plant rooms) and a reduction in the amount of kilowatts peak (kWp) generated.
Modification 5	8 June 2021	Minor modification to correct plan revisions and dates.
Modification 6	29 September 2021	Fit-out, use and operation of the eastern mezzanine of the stadium for the purpose of a dedicated training and administration facility for the Sydney Roosters NRL football club, known as the Sydney Roosters Centre of Excellence.
Modification 7	18 July 2022	Construction of a Precinct Village and 1,500 space multi-level carpark adjacent to the new stadium, incorporating a single storey retail pavilion, four tennis courts, landscaping and the

		reconfiguration of stadium pedestrian and vehicular access.
Modification 8	15 December 2023	This modification aims to achieve the following: <ul style="list-style-type: none"> - Increase concert events within Sydney Football Stadium from 6 to 20 per year. - Increase concert lengths from 5 hours to 10 hours (twice per year). - Alter rehearsal and sound test finish time from 7pm to 10pm. - Curfew exemption from Mardi Gras.
Modification 9	21 May 2024	Modified Precinct Village and multi-level carpark staging
Modification 10	17 March 2025	Changes to multi-level carpark and design refinements

SSD 9835 MOD 10 was determined by the Department of Planning, Housing and Infrastructure on 17 March 2025 which provided approval to:

- reconfigure the basement car park structure by increasing the depth of excavation on the western side and constructing an additional level on the eastern side of the car park, resulting in an increase in the depth of excavation by 3m from existing level
- revise Level B4 of the basement to partially accommodate retention of the rock section of the shaft
- remove car parking spaces from the mezzanine level on the east to provide a double height 'boneyard' space to facilitate on site bump in and bump out requirements for events
- reconfigure the Plaza to facilitate interpretation of the newly discovered shaft
- reconfigure the Plaza to satisfy conditions of consent requiring compliance with the Everyone Can Play Guidelines and approved tree retention and planting regime
- incorporate a suite of detailed design refinements across the site reflecting the design development process. such as fire stair and plant room rationalisation. In accordance with Condition B2 of the consent (as modified), the CWSMSP must be prepared by a suitably qualified and experienced person(s) and in consultation with Council prior to commencement of construction. The CWSMSP must be approved by the Certifying Authority and a copy submitted to Council and the Planning Secretary for information prior to the commencement of any works. In addition, all mitigation and management measures identified in the CWSMSP, must be installed or implemented where reasonable and practical on the site prior to commencement of works on site.

This development will transform the Moore Park Precinct, offering visitors year-round access to quality food and beverage offerings linked with adjacent open spaces for gatherings and organised events. The development will enhance the Moore Park Precinct amenity, creating greater vibrancy and patronage year-round.

4 Potential Impacts

Construction activities occurring on site may result in the following negative impacts to soil and water:

- Soil contamination;

- Soil erosion; and
- Water pollution.

5 Soil and Water Management Objectives

The following soil and water management objectives will apply to construction activities:

- Minimise pollution of surface water through appropriate erosion and sediment control measures;
- Ensure that all contaminated soil is managed in accordance with relevant legislation and the Spoil Management Plan Sampling, Analysis & Quality Plan (SMPSAQP);
- Maintain existing water quality of surrounding surface watercourses;
- Ensure no uncontrolled surface water run-off from the site into stormwater drains;
- Re-use 100% of spoil that can be reused in the project; and
- Mitigate flooding risk through an engineered approach with robust planning and controls.

6 Roles and Responsibilities

6.1 Key BESIX Watpac Personnel

An overview of the specific responsibilities of the BESIX Watpac project team for water and soil management as they relate to each role on the project are outlined in 2 below:

Table 3 Roles and Responsibilities

Role	Authority and Responsibility
Project Director Construction Managers	<ul style="list-style-type: none"> Manage the delivery of Moore Park PV&C including overseeing the implementation of the CWSMSP , associated sub-plans and procedures Authority to discharge water offsite under the Controlled Overflow Strategy
Site Manager Project Engineers Construction Foremen	<ul style="list-style-type: none"> Oversee the implementation of all environmental, soil, water and groundwater management initiatives Report on environmental performance Authority to direct personnel and subcontractors to carry out actions to avoid or minimise environmental impacts Review of water quality monitoring reports (CWQMR) prepared by the water quality monitoring consultant Conduct an investigation in the event of a water quality exceedance Authority to discharge water offsite under the Controlled Overflow Strategy
Sustainability Manager	<ul style="list-style-type: none"> Daily weather monitoring Visual inspection to establish whether mitigation measures are required On site environmental monitoring and visual inspections of mitigation measures in place Records keeping and reporting in implemented mitigation measures Collection of water quality samples and undertaking of field analysis of certain samples collected Coordinate on site testing with agencies undertaking testing and laboratories analysing sampling results
Commercial Manager	<ul style="list-style-type: none"> Visual inspections of mitigation measures in place Establishment of mitigation measures Record keeping in relation to mitigation measures Ensure compliance with the CEMP and soil and water procedure Conduct inductions and toolbox talks in relation to soil and water responsibilities Authority to direct personnel and subcontractors to carry out actions to avoid or minimise environmental impacts Authority (Site Manager only) to discharge water off site under the Controlled Overflow Strategy
	<ul style="list-style-type: none"> Track and report soil and water elements against sustainability targets
	<ul style="list-style-type: none"> Ensure that relevant soil and water and groundwater management requirements are considered in procurement

6.2 Specialist Consultants

6.2.1 Contamination & Acid Sulphate Soils Expert

BESIX Watpac have engaged Douglas Partners, a consultancy specialist in geotechnical, environmental and groundwater engineering, to carry out additional investigations and provide general geotechnical advice and geotechnical services, as well as groundwater quality testing and contamination services. Douglas Partners will prepare a Remediation Action Plan (RAP) and a Long-Term Environmental Management Plan (LTEMP) if required.

6.2.2 Water Quality Monitoring

BESIX Watpac have engaged Douglas Partners to complete groundwater quality testing. This is likely to include sampling and testing groundwater prior to disposal of nominated points in the Dewatering Management Plan and the provision of regular reports to ensure compliance with the Dewatering Management Plan.

7 Soil Management

The following mitigation measures will be implemented during construction to minimise potentially adverse impacts on soil:

7.1 Contamination and Acid Sulfate Soils

Extensive environmental investigations, and remediation, have been undertaken in the Moore Park area in the vicinity of the PV&C as summarised in Table 4 below:

Table 4 Summary of Key Environmental Investigations undertaken in the vicinity of Moore Park Precinct Village and Carpark

No	date	Author	Title	Scope/Purpose	Comment
1	September 2021	Douglas Partners	SSD 9835 Sydney Football Stadium Redevelopment Section 4.55 Modification Precinct Village and Car Park (MOD 7) Contamination	Memorandum of the considerations of contamination at the Precinct Village and Car Park site given the contamination on the SFS site.	Memorandum requested by VNSW
2	December 2021	Douglas Partners	Report on Geotechnical Investigation – Precinct Village and Carpark – Stage 1	The geotechnical investigate included seven cone penetration tests (CPTs), the drilling of seven vertical cored boreholes, one inclined borehole, the installation of one groundwater monitoring well, laboratory analysis and engineering interpretation.	Commissioned by John Holland
3	August 2022	Douglas Partners	Report on Detailed Site Investigation (Contamination)	Investigation included a review of site history from previous investigations and field work comprising soil sampling from a total of 32 test locations.	Commissioned by John Holland
4	September 2022	Douglas Partners	Report on Geotechnical Investigation- Precinct Village and Carpark – Stage 1 (West)	The geotechnical investigation included the drilling of 14 vertical cored boreholes, one inclined cored borehole, the installation of three groundwater monitoring wells, laboratory analysis and engineering interpretation. Two Stage 2 boreholes (BH1.3 and BH1.6), cone penetration tests (CPT1.3 and CPT1.6), and groundwater well BH1.1, are relevant for the Stage 1 works and are also included in the report.	Commissioned by John Holland
5	September 2022	Douglas Partners	Ground Inflow Assessment Precinct Village	Report presents the results of a groundwater inflow assessment for the operational phase (post-	Prepared for John Holland

No	date	Author	Title	Scope/Purpose	Comment
			& Carpark – Stage 1	construction) of stage 1 (western portion) of the proposed Precinct & Village & Carpark (PV&C) project.	

The ‘Detailed Site Investigation (Contamination), Sydney Football Stadium: Members Carpark Report’ notes that ACM was detected in one location and lead was detected in one location in excess of the adopted SAC. The lead exceedance was not considered to be significant based on the calculated 95% UCL of lead in fill which was within the adopted SAC. Exceedances of the EIL were also detected however these were not considered to be significant. The report also notes based on the nature of the fill (significant building demolition and other anthropogenic materials) it is considered that there is a moderate to high risk that asbestos may be present at the site beyond the one location where it was positively identified. The fill was provisionally classified as general solid waste with the exception of fill within the vicinity of the test pit TPC which was classified as Special Waste (asbestos).

BESIX Watpac has engaged Douglas Partners as the specialist consultant responsible for the preparation of a Remediation Action Plan (RAP) to ensure that the off-site disposal and other services are undertaken in an appropriate manner, and the preparation of a Long-Term Environmental Management Plan (LTEMP) to update the one that currently exist for the site due to the change in site conditions. Additionally, Douglas Partners will conduct additional investigations including fieldwork and laboratory testing prior to construction. Furthermore, Douglas Partners will prepare a Dewatering Management Plan and will conduct a series of inspections during the piling phase of the project.

7.2 Waste Classification and disposal

Soils to be disposed of off-site will be classified in accordance with the POEO Act (including the NSW EPA Waste Classification Guidelines, where applicable) prior to leaving the site.

Each excavated area / stockpile will be tracked on the Material Tracking Register to identify where the material was excavated from and document the soil classification and volumes of each stockpile. The Material Tracking Register will be read in conjunction with a site map mark-up of the stockpiles, to assist in managing where material was excavated from and tracking the different classification of materials on site. Once waste classification reports are issued, it will be determined whether the spoil can be reused, or whether it needs to be taken to a licenced landfill in accordance with the SMPSAQ and ASSMP. All material that is taken to licenced landfills will be tipped at locations licenced to take the classification of spoil. Tipping dockets from the licenced landfill will be provided by the civil subcontractor and be recorded in the Material Tracking Register. Waste Classification Report references will also be recorded in the relevant section of the Materials Tracking Register.

7.3 Unexpected Contamination

Where unexpected contamination in the form of contaminated soil, ASS or asbestos is discovered on site, the SMPSAQ outlines the process to be followed to mitigate environmental risks from unexpected contamination.

7.4 Erosion & Runoff

Erosion and sediment control measures will be implemented in accordance with *Managing Urban Stormwater: Soils and Construction Volume 1* (Landcom, 2004) and *Managing Urban Stormwater: Soils and Construction Volume 2* (Department of Environment and Climate Change, 2008a) Measures will be

designed as a minimum for the 80th percentile, 5-day rainfall event. Control measures will be placed downstream of stockpiles and disturbed excavation works and stockpiles will not be located in drainage lines, channels or overland flow paths.

Progressive Erosion and Sediment Control Plans (ESCPs) will be developed and implemented to detail all required erosion and sediment control measures for the site prior to any works commencing. ESCPs will be updated progressively throughout the project to reflect the current and changing site conditions. Any amendments to the ESCP will be approved by the Planning and Environment Manager.

7.5 Soil Monitoring

Monitoring activities, as outlined in Table 5 will be implemented during construction to minimise adverse impacts to soil and testing of excavated material will be undertaken in accordance with the SMPSAQ:

Table 5 **Monitoring Activities**

Monitoring Activities	Frequency
Inspections of erosion and sediment control measures in place including a record of issues identified and rectification	Weekly and before any significant inclement weather event
Additional inspections will be undertaken prior to and following significant rainfall events, classed as greater than 20mm over a 24-hour period	Prior to and following significant rainfall events (>20mm in 24 hours)

7.6 Material Importation

Soil imported to the site will meet the following requirements:

- The soil must be legally able to be imported onto the site in accordance with the *Protection of the Environment Operations (Waste) Regulation 2014* and any required works specific approvals.
- The soils must meet the geotechnical requirements for their proposed use.
- The soils must be classified as VENM, Excavated Natural Material (ENM) or other materials legally able to be imported onto the site based on a Resource Recovery Order and Exemption. Soils must be assessed in accordance with the EPA requirements. For VENM this generally includes having no signs of concern, metal concentrations at background levels and organic compounds below appropriate laboratory limits of reporting. For non-VENM materials the EPA requirements would generally include assessment in accordance with the appropriate Resource Recovery Order. Prior to importation, appropriate documentation should be provided to, and approved by, the Environment and Planning Manager or Construction Manager and the materials should, where practicable, be inspected at the source site to confirm that there are no signs of contamination. Quarried materials (i.e., materials sourced from a quarry that are not recycled) need not be subject to assessment by the Environmental Consultant, however other inspection and record keeping requirements still apply to these materials.
- The material must be inspected during importation, and any materials not meeting the description given in the provided documentation or displaying signs of contamination will be rejected. The Environmental Consultant may also conduct inspections during and / or following importation to check the same.
- Additional testing of the imported material may be required, as recommended by the Environmental Consultant, commensurate with the documentation provided for review and the material type/ classification. The contractor will track and keep a record of all soil materials imported onto the site in the material tracking register.

8 Soil and Water Quality Action Planning

Design and Planning	Staff Responsible	When
<p>The risks associated with the management of erosion and sedimentation in relation to particular construction activities are to be identified, and mitigation controls elected in accordance with the BESIX Watpac Environmental Risk Assessment.</p>	<p>Site Foreman</p>	<p>Prior to start of each construction activity</p>
<p>As works proceed throughout construction staging, the ESCP is to be amended where necessary to be relevant and effective for site conditions and active work areas.</p>	<p>Project Engineer</p>	<p>At all times</p>
<p>Design and installation of erosion and sediment control devices would be undertaken in accordance with the document Managing Urban Stormwater – Soils in Construction Volume 1 ‘Blue Book’ (2004, Landcom). Controls are to be downstream of exposed or disturbed areas and adjacent to the on-site stormwater drainage lines and located within the project footprint upstream of Kippax Lake. Erosion and sediment controls are to consider the management of stormwater and flood flows for small and large sized events, including, but not limited to a 1 in 1-year ARI, 1 in 5-year ARI and 1 in 100-year ARI. Examples of erosions and sediment controls to be implemented may include, but are not limited to:</p> <ul style="list-style-type: none"> • Physical demarcation of ‘no-go’ zones in order to retain existing vegetation / groundcover. • Reinstating groundcover and progressively stabilising disturbed areas once works are complete in a zone or area. • Sediment basins. • On-site detention (OSD) structures such as Driver Avenue existing OSD and Fox Studio box culverts (via SG basement). • Clean and dirty water diversion drains. • Rock checks within diversion drains. • Sandbags, gravel socks and/or geo-fabric. • Sediment fences; and • Sterile straw bales and/or coir logs. <p>Note: The 5-day, 85 percentile rainfall limits under the ‘Blue Book’ are 38.8mm for the site</p>	<p>Project Engineer</p>	<p>Prior to commencement of construction works, Site Establishment activities and always maintained and thereafter.</p>
<p>Appropriate controls for erosion and sediment control should be determined by considering:</p> <ul style="list-style-type: none"> • Local climatic conditions and seasonal variations. • Soil types, particularly dispersive, sodic, and saline soils. • Local hydrology affecting the construction zone. • Local drainage, including temporary and overland flow paths and quantities Availability of existing onsite structures (OSD) 	<p>Project Engineer</p>	<p>At all times</p>

Erosion and sediment controls should be designed to direct run-off away from the superstructure and direct flow towards Driver Avenue.	Project Engineer	Prior to start of works – Site Establishment activities
Following rain events, the effectiveness of erosion and sediment controls to be reviewed, controls adjusted accordingly, and plans updated as required.	Project Engineer	Throughout works
ESCP's would be periodically updated by the PER following significant change in site conditions during civil works. These would be reviewed in consultation with the Soil Conservationist	Project Engineer	Civil Works

Pre-Construction	Staff Responsible	When
An initial ESCP developed by a recognised Soil Conservationist would be developed for the Project.	Project Engineer	Prior to commence of construction
Erosion and sediment controls are to be installed in accordance with the approved ESCP(s).	Project Engineer	Prior to commencement of construction works and until site reaches stabilisation
A stabilised construction access / egress will be established where construction traffic enters or leave from a public road.	Site Manager	At start of works
Stabilised access would include wheel wash facilities for the duration of the civil works on-site.	Site Manager	Civil works
Clearing of vegetation shall be planned in accordance with approved design documentation and undertaken in a staged manner to ensure a minimum amount of bare ground is exposed at any one time.	Site Manager	At start of works
Clearly mark out the development footprint including signage to ensure clearing, and earthworks remain within these boundaries.	Site Manager	At start of works

Plant Movement and Access	Staff Responsible	When
Vehicles are to remain on the designated roadways and observe the speed limits.	All personnel	At all times
During civil and excavation works, plant will be required to park in designated lay-down zones when not in use, located in a central location on the site and beyond the 1% AEP (Annual Exceedance Probability) flood line where significant rain events are predicted.	Site Foreman	At all times
During periods of wet or hot and dry conditions, construction activities and plant movements to be limited such as to minimise the movement of vehicles on site during these periods.	Site Forman	As required
Tracking of spoil, mud or the like will be required to be monitored daily, and if occurring, consider installation of	Site Manager	Daily

additional controls such as rumble grids to reduce entrained material on tracks and tyres.		
Spoil, mud or the like spilt onto internal sealed roads to be removed within a reasonable timeframe through use of a street sweeper or other means.	Site Foreman	At all times

General Requirements	Staff Responsible	When
Washout facilities must be in place and used for cleaning plant and equipment, concrete, paint, or other environmentally hazardous substances.	Site Foreman	At all times
Water diversion controls must be in place to prevent water entering the work area to minimise erosion and prevent pollution.	Site Foreman	At all times
Areas of exposed earth must have erosion and sediment controls designed, installed, maintained, and continually monitored for effectiveness.	Site Foreman	At all times
The Erosion and Sediment Control Plan would be updated where required by the Environmental Team as the site changes through construction staging.	Site Foreman	As required during earthworks
All project personnel shall be made aware of erosion and sediment control devices and equipment at induction and the ESCP is to be displayed in prominent location at site sheds.	Site Foreman	At induction and always
All project personnel to be made aware of the use of available spill kits in response to spills and/or leaks.	Site Foreman	At all times
Erosion and sediment controls shall be cleaned or replaced prior to accumulated sediments and obstructions reducing their effective operating capacity by 60%. Controls which are damaged or otherwise rendered ineffective shall be immediately replaced.	Site Foreman	At all times
Prolonged open excavations shall have berms and/or diversion drains on their perimeter to divert overland storm water runoff away from the excavation. Where appropriate, utilise sandbags and/or geofabric to reduce flow velocity and minimise erosion within the drainage channel.	Site Foreman	At all times
Erosion and sediment control decisions shall be made to encompass reasonable and practical prevention, and will consider the receiving environment, water quality objectives, quality and quantity of water, location and accessibility, and other requirements.	Site Foreman	At all times
All stormwater drainage inlets within the site and other discharge points where there is potential for sedimentation to occur because of construction activity shall be protected by geofabric and/or sandbags as appropriate in accordance with the ESCP.	Site Foreman	At all times
The PER will provide direction for the location, installation, maintenance, and removal of erosion control devices in accordance with the ESCP.	Site Foreman	At all times

Any trenches excavated will be backfilled as soon as practicable after services have been laid.	Site Foreman	At all times
Connect downpipes to the stormwater drainage system as soon as roofing is completed.	Site Foreman	Once roofing is completed
Concrete washout activities will be carried out within designated sealed bunded areas or carried out off-site. All construction water will either be treated to appropriate levels for reuse or be removed from site to an appropriately licensed facility.	Site Foreman	During concrete works
Concrete waste and rinse water are not to be disposed of on the site and must be prevented from entering any natural or artificial watercourse or waterbody as outlined in the Appendix A.	Site Foreman	During concrete works

Stockpiling, Stabilisation, Rehabilitation and De-mobilisation	Staff Responsible	When
Suppress earthworks, batters, access tracks and other exposed areas with a bonding agent or water on dry windy days to minimise soil erosion and dust in accordance with requirements in the Construction Air Quality Management Sub Plan.	Site Foreman	At all times
Where suitable, sediment fencing shall be installed around the perimeter of exposed/disturbed soil stockpiles and at the toe of exposed batters.	Site Foreman	As appropriate
Stockpiling locations will be outside the drip line of trees and will be kept on non-permeable surfaces.	Site Manager	At all times
Stockpile locations will be in areas not prone to flash flooding and away from drainage lines and diversion drains as far as practicable.	Site Manager	At all times
Imported materials, and excavated materials of different types must be separately stockpiled, stabilised and/or bunded, and clearly labelled with laminated sign on star picket.	Site Foreman	At all times
All imported material will be recorded on a truck running sheet that will record time, date, truck registration, truck size (volume), source site and visual description of material. The placement location on site will be recorded.	Site Foreman	At all times
All material for export is to be managed in accordance with NSW Waste Classification Guidelines (NSW EPA, 2014). All exported material will be sampled.	Site Foreman	At start of works and throughout the works
Rehabilitate areas progressively throughout construction, as activities are complete in areas, and immediately on completion of works where practicable.	Site Manager	Throughout the works and on completion of works

Imported Soil	Staff Responsible	When
Imported soil must be VENM, ENM, meet a current resource recovery exemption or other material approved in writing by EPA. All imported material must be approved by the Site Auditor.	Site Manager	At all times
Imported material will be sampled in accordance with the RAP.	Site Manager Subcontractor	At all times
Imported topsoil for the playing field inside the stadium must meet the Recreational / Recreational Open Space criteria defined in Schedule B1 of the National Environmental Protection Measure, As Amended (NEPC, 2013).	Site Manager	At all times
All imported material will be recorded on a truck running sheet that will record time, date, truck registration, truck size (volume), source site and visual description of material. The placement location on site will be recorded.	Site Foreman Subcontractor	At all times
Maintain accurate records of the volume and type of material(s) imported to site. These records are to be made available to the Department and the Certifying Authority upon request.	Site Foreman	At all times

Potential Acid Sulphate Soils (PASS)	Staff Responsible	When
The results of testing and the understanding of the history of the formation of these soils on site do not indicate the typical formation of Acid Sulphate Soils. This is because the soils do not contain sulphides and are non-estuarine in origin. The NSW Office of Environment and Heritage Acid Sulfate Soil Risk Map does not identify the site as being at risk of acid sulfate soils, or for these soils as being in vicinity of the site. The site is also not mapped as being at risk of soil salinity, and the data acquired from bores demonstrates that salinity levels are indicative of 'fresh' water quality. If Acid Sulphate Soils (ASS) or Potential Acid Sulphate Soils (PASS) are thought to be uncovered throughout construction, these will be dealt with under the unexpected finds protocol.	Site Manager	Prior to commencement of works.

Management and Removal of Excavated Materials	Staff Responsible	When
Excavated materials of different types must be segregated, stockpiled, stabilised and/or banded, and clearly labelled with laminated sign on star picket.	Site Foreman	At all times
Topsoil will be stockpiled separately from other materials on site.	Site Manager	At all times
Topsoil will be reinstated as soon as practicable.	Site Manager	At all times
Dispersive (sodic) soils to be treated and managed appropriately to address its stability, structure, and potential mixing with adjacent materials.	Site Manager	At all times

All stockpiles to be inspected immediately following the cessation of rainfall to assess stability and remedial works undertaken as soon as safe to do so.	Site Manager	Post Rainfall
Replace soils in their original order if excavations are undertaken to ensure that materials are buried appropriately.	Site Manager	At all times
Re-direct water away from areas where dispersive (sodic) subsoils have been exposed or stockpiled.	Site Manager	At all times
Bulk earthworks on-site will not commence until the erosion and sediment controls are in place as per the ESCP for the works.	Site Manager	At start of works
<p>All contaminated and non-contaminated material to be excavated onsite shall be managed in the following manner:</p> <ul style="list-style-type: none"> Where disposal is required off-site, material is to be managed in accordance with NSW Waste Classification Guidelines (NSW EPA, 2014). Re-use / Placement elsewhere on site, material is to be managed in accordance with NEPM (Assessment of Site Contamination) 1999. Any material that contains asbestos would be classified as Special Waste – Asbestos if being removed from site. Special Waste Asbestos is to be tracked with NSW EPA Waste Locate to comply with clause 79 of the Protection of the Environment Operations (Waste) Regulation 2014. 	Site Foreman	At start of works and throughout the works
The widespread presence of ash in the filling allows the soil to be classified based on the leachable concentrations of PAH and Benzo(a)pyrene in accordance with the General Approval of the Immobilisation of Contaminants in Waste 1999/05 issued under Clause 101 of the Protection of the Environment Operations (Waste) Regulation 2014.	Site Foreman	At all times
If excavations uncover or are suspected to have uncovered contaminated soils (including asbestos or ASS / PASS) due to staining/odours, works are to cease immediately in the area and the SM and PER contacted and the unexpected finds protocol (Appendix D) followed. Specialist advice may be required to test and classify soils.	Site Manager	At all times
Movement of material off-site would be undertaken as part of waste tracking procedures under the waste management plan.	Site Foreman	At all times
All materials leaving the site will be recorded on a tracking sheet which will be reconciled with landfill docket.	Site Foreman	At all times
All contaminated spoil and/or materials will be contained in appropriate contaminated waste containers or bins prior to remediation or offsite disposal at an appropriately licensed facility. If material is unable to be contained, it will be stockpiled on a bunded, impermeable surface and covered.	Site Foreman	Where contamination is encountered

Implement any control measures required to divert surface water run-off away from contaminated materials onsite, and appropriately manage any surface run-off water exposed to contaminated material.	Site Foreman	Where contamination is encountered
---	--------------	------------------------------------

Materials Handling and Storage	Staff Responsible	When
When planning the location of facilities, plant laydown areas, refuelling areas, stockpiles, or chemical storage areas that drain towards surface water (i.e., Kippax Lake) or stormwater systems must be avoided in order to minimise risk of pollution. Any higher risk items (i.e., Generators) must be in a bunded location.	Site Foreman	At all times
All fuels, chemicals, and liquids will be stored at least twenty meters away from waterways (including existing stormwater drainage system) and will be stored in a sealed bunded area.	Site Foreman	At all times
Chemicals and fuel must be labelled and stored in accordance with the safety data sheets (SDS) requirements.	Site Foreman	At all times
Spill kits and fire response equipment must be located where chemicals and fuelled plant or equipment is being stored, operated, or maintained.	Site Manager	At all times
No refuelling, stockpiling or chemical storage to occur near stormwater drainage pits.	Site Foreman	At all times
Refuelling activities would be conducted in accordance with an approved TRA.	Site Foreman	At all times
The location of spill kits will be provided on the Site Environmental Plan.	Site Foreman	At all times
Spill kits (site kits or plant kits) to be in close proximity to machines refuelling or chemical storage locations.	Site Foreman	At all times
A copy of the EPA Storing and Handling Liquids: Environmental Protection Participants Manual will be kept onsite for the duration of the project (this document supersedes EPA Bunding and Spill Management Guidelines).	Site Foreman	At all times
A site-specific Emergency Response Plan will be developed for the project, with consideration of spill response management.	Project Manager	Prior to works commencing

Dewatering and Discharge	Staff Responsible	When
In the event that groundwater is intercepted during construction works and dewatering is required, written approval and relevant licences must be obtained from the relevant authorities (such as the Water Group within the Department (i.e., DPIE) or Council's Public Domain Unit for any discharge of groundwater into Council's stormwater system)	Site Manager	If dewatering of groundwater requires discharge from site and prior to discharge

All dewatering systems must be planned and monitored to avoid spills, overflows, and pollution.	Site Manager	Prior to works commencing and throughout the works
All run off emanating from the site must be effectively filtered or otherwise treated so that the water quality meets water discharge limits specified in Section 4.2.	Site Manager	At all times
No discharge of surface or groundwater is to occur unless the water quality is within project Water Quality limits set out in Section 4.2. Where compliance with Water Quality limits is not met, water shall be treated as per corrective actions in Section 10. Field testing by the Site Manager shall record compliance with project WQOs prior to discharge.	Site Manager	At all times
Dewatering activities shall not take place unless a Dewatering Permit has been obtained and completed to the satisfaction of the Site Manager.	Site Manager	At all times
All personnel involved in discharge of water from site would be appropriately trained including in monitoring, treatment, and is charge requirements	Site Manager	At all times
Wet Weather Events (Stormwater & Flooding)	Staff Responsible	When required
Daily monitoring and long-term forecasting of activities referencing Bureau of Meteorology forecasts and NSW rain and river data and flood warnings. Relevant information is to be conveyed in toolbox talks and on-site notice boards and construction activities re-scheduled where necessary.	Site Manager	At start and throughout the works, daily.
Where possible, working and storage areas and any proposed stockpile sites would be located above the 100-year ARI peak flood level.	Site Foreman	At all times
Temporary works such as hardstand areas and access tracks are to be designed, constructed, and maintained to withstand flooding.	Site Manager	Prior to works commencing and throughout the works
Erosion and Sediment control measures are implemented as per Appendix B – Site Specific ESCP.	Site Manager	Prior to works commencing and throughout the works
Ensure constructed access tracks are free draining from crown of track to shoulder edge to decrease delays from re-access following wet-weather events and conduct temporary repairs to access tracks to reduce long term damage where possible.	Site Manager	Prior to works commencing and throughout the works
Implement non-structural measures to wet-weather response onsite. These measures do not change flooding behaviour but alter how people and property are affected by wet-weather events. The following mitigation measures would be implemented: a) Wet-weather and flood awareness training	Site Foreman	Prior to works commencing and throughout the works

<p>b) Pre-start briefings / toolbox talks held daily and summarising the forecast predictions provided by Site Manager</p> <p>c) Daily monitoring of weather conditions and long-term forecasting of construction activities.</p>		
<p>Work should not take place during or after heavy rain when doing so is likely to cause soil erosion or soil structural damage or result in indirect impacts to any neighbouring vegetation or riparian corridors.</p>	Site Manager	At all times
<p>Following rain events (+20mm over 24hrs), the effectiveness of erosion and sediment controls to be reviewed, controls adjusted accordingly, and plans updated if required.</p>	Site Manager	Following rainfall event
<p>Specific measures to manage flood flows for small and large sized events, including, but not limited to 1 in 1-year ARI, 1 in 5-year ARI and 1 in 100-year ARI include:</p> <p>a) storage of hazardous materials away from flow paths and known drainage channel</p> <p>b) layout of site compound facilities to take into consideration of the flow paths.</p> <p>c) ensure evacuation routes are kept clear during high-risk periods.</p> <p>d) ensure loose materials, fuel, chemicals, and equipment can either be secured or removed during a flood event if required.</p>	Site Manager	As required

Management of Fine Particulates to Sensitive Areas (Stormwater Entrainment)	Staff Responsible	When
<p>Implementation of the mitigation, management and monitoring measures as detailed in the Construction Air Quality Management Sub Plan (CAQMSP) will support the effort to ensure fine particulates (and dust in general) is not deposited in areas where it can be entrained in stormwater runoff</p>	Site Manager	Prior to works commencing and throughout the works
<p>In terms of soil and water management, temporary swale drains, and temporary sediment basins will be designed in accordance with applicable guidelines e.g., Blue Book (Landcom, 2004). Basins and temporary swale drains will be appropriately lined to prevent infiltration of fines to groundwater or impacts on downstream sensitive areas.</p>	Site Manager	Prior to works commencing and throughout the works
<p>Where feasible and reasonable, catchment areas outside the main civil footprint may be broken up into catchment areas (and within work zones where appropriate) to reduce the risk of fine particulates leaving site and impacting on Kippax Lake, downstream properties, and groundwater resources. Measures employed may include but not limited to:</p> <ul style="list-style-type: none"> • Temporary stabilisation or revegetation/management works to reduce the extent of disturbed surfaces. • Application of temporary surface treatments or blanketing on exposed earth surfaces • Sediment barriers 	Site Manager	During earthworks

<ul style="list-style-type: none"> Stabilised drainage lines incorporating rock check dams at regular intervals. Multiple temporary sediment sumps will be created within boxed out/disused (cricket nets) areas to minimise the risk of all onsite dirty water running to live stormwater pits during rainfall. <p>Measures would be detailed in the ESCP for the works.</p>		
Sediment controls will be de-silted (cleaned out) as required within 5 days following rainfall to ensure they have adequate capacity and are ready for the next rainfall. Material removed from sediment controls will be placed on a stockpile or into general fill.	Site Manager	During Works
All stormwater drainage inlets and other discharge points where there is potential for sedimentation to occur because of construction activity shall be protected by geofabric and/or sandbags as appropriate.	Site Manager	Prior to works commencing and throughout the works
Sediment controls such as sediment fences, check dams, inlet protection, mulch bunds, coir logs or sediment traps will be installed around the lower perimeter of work areas where dirty onsite water could run off.	Site Manager	Prior to works commencing and throughout the works
Use geotextile linings, black plastic, organic fibre matting, rock or similar to provide temporary surface protection in areas of concentrated flows (e.g., working platforms).	Site Manager	During works
As much as possible, separate 'clean' (offsite) run-on water from 'dirty' (onsite) construction area runoff. All dirty water must be graded to or directed to sediment controls.	Site Manager	Prior to works commencing and throughout the works
Construction Activities would be staged and managed to ensure no sediment is transferred to the adjacent streets or introduced into the existing stormwater drainage lines which could impact on Kippax Lake.	Site Manager	Prior to works commencing and throughout the works
Other sediment control measures to be implemented (as appropriate) include sediment fences, straw bales, coir logs, fabric stocking sediment traps around existing pit/drain inlets, diversion banks and truck shaker grids at points of exit.	Site Manager	Prior to works commencing and throughout the works
BESIX Watpac has engaged a Certified Professional in Erosion and Sediment Control (CPESC) to support its development of an overarching Erosion and Sediment Control Plan (ESCP).	Site Manager	Prior to works commencing and as required throughout the works.

Monitoring Required	Staff Responsible	When
General observations for the daily management of erosion and sediment controls shall be documented in site dairies.	Site Foreman	Daily as Required
Regular visual water quality checks in stormwater pits on-site and Kippax Lake (for turbid plumes and hydrocarbon spills or) will be carried out on a weekly basis and post rainfall event during civil construction activities. If a plume or spill is	Site Foreman	As required

detected, it would be investigated to determine the source and if attributable to the Project.		
Regular inspection of erosion and sediment controls shall be undertaken using the Weekly Environmental Management Inspection Checklist and uploaded to Project Pack Web.	Site Foreman	Weekly and during and after storm events >10mm in 24 hours
Effectiveness of erosion and sediment controls shall be regularly reviewed for adequacy having regard for changing circumstances.	Site Manager	Throughout works
The project specific Discharge Checklist is to be used prior to discharge of water from site where and records to be kept in Project Pack Web. Monitoring of water quality is to be undertaken in accordance with Appendix A – Water Quality Management Manual (WQMM).	Site Foreman	Prior to discharge
Prior to any off-site discharge, water to be tested and adjusted as appropriate to meet WQO limits as specified in Section 19 of the water quality management Appendix.	Site Manager	Prior to discharge
Water quality monitoring results to be maintained in BESIX Watpac document management system (Aconex) and made available to agencies upon request.	Site Manager	As required

Reporting Required	Staff Responsible	When
Details of field observations shall be reported via the Enviro Inspection Checklist, and communicated to all staff during pre-starts, toolbox and/or team meetings.	Site Manager	All times
All complaints / incidents regarding soil & water shall be reported immediately to the PER.	All Staff	Following receipt of incident/complaint
The Project Director shall be notified immediately of all incidents and valid complaints. Relevant BESIX Watpac procedures for incidents and complaints handling reporting shall be followed.	Site Manager	Following receipt of incident/complaint
BESIX Watpac NSW WHSE Team is to be immediately informed of any incident that has caused or is likely to cause material harm to the environment and will advise on the notification of relevant regulators and stakeholders (As required by the Protection of the Environment Operations Act 1997).	Project Director	Following Incident
The BESIX Watpac Project Director shall notify the client of all significant incidents and valid complaints, verbally within 2 hours, and in writing within 24 hours.	Project Director	Verbally within 2 hours, and in writing within 24 hours
All monitoring results are to be recorded on the BESIX Watpac internal record system (Aconex). Agencies will be provided results if requested,	Site Manager	Throughout works

A summary of soil and water management to be included in the project monthly environmental report and issued to the Project Director.	Project Manager	Monthly
A summary of incidents, valid complaints and monitoring results (if any) shall be provided monthly to the client and include the actions that were taken to address the incident/complaint.	Project Manager	Monthly

9 Environmental Planning & Flooding

Uncontrolled overland flow of water or unmanaged stormwater could potentially lead to flooding and environmental impact to the project and the adjacent waterway. The environmental impact and mitigation measures are outlined below in Table 6.

Table 6 Flood impact and migration measures

Environmental Aspect	Potential Impact	Mitigation Measure
Rainfall in excavated areas/zones	<ul style="list-style-type: none"> Rainfall falling into trenches or excavation hole 	<ul style="list-style-type: none"> Detail construction planning including the development and implementation of ESCPs . Emergency Discharge Procedure – Controlled Overflow Strategy
Flooding during extreme rainfall from adjacent roads and stormwater systems	<ul style="list-style-type: none"> Currently stormwater accumulates at a shallow depth across the car park with flow generally travelling north to south and draining via the drainage network when capacity is available. Extreme rainfall could impact excavation and piling, and watering entering the carpark structure requiring de-watering 	<ul style="list-style-type: none"> Temporary civil engineer to review rainfall quantities and temporary pumping needed to mitigate flooding effects and ensure capacities of pumps can accommodate rainfall
Localised flow paths causing nuisance flooding on the worksite	<ul style="list-style-type: none"> Nuisance flooding as result of localised overland flow paths could make the worksite un-trafficable in areas of excavation for workers. 	<ul style="list-style-type: none"> Diversion drains and swales will be implemented in the ESCPs

10 Spill Response Management

Spill prevention measures and monitoring will be adopted as outlined below and in accordance with the BESIX Watpac Spill Response Management Procedure (F.8):

9.1 Spill Mitigation Measures

- Dangerous goods and hazardous chemicals including fuel to be stored within bunded areas.
- Chemicals and fuel to be labelled and stored in bunded areas in accordance with the safety data sheet (SDS).
- Spill kit and fire response equipment to be located where chemical and fuel using plant or equipment is stored or operated and outlined in Environmental Control Maps (ECMs)
- All hazardous chemicals are to be stored and managed in accordance with the NSW *Work Health and Safety Regulation 2017*, the NSW Code of Practice for Managing Risks of Hazardous Chemicals in the Workplace 2019, and the NSW Code of Practice for Labelling of Workplace Hazardous Chemicals 2019.
- Spill kits will be provided on site

9.2 Storage and Handling – Hazardous Chemicals

Hazardous chemicals, must be stored and handled strictly in accordance with:

- All relevant Australian Standards and legislation
- *Storage and Handling Liquids: Environmental Protection – Participants Manual* (Department of Environment and Climate Change, May 2007)
- The *Environmental Compliance Report: Liquid Chemical Storage, Handling and Spill Management – Part B Review of Best Practice and Regulation* (Department of Environment and Conservation (NSW), 2005)

11 Record Management

Records will be maintained by the project Planning and Environment Manager and Environmental Co-ordinator and transmitted to VNSW via Aconex for compliance tracking purposes, as follows:

- Copies of current ESCPs for all active construction sites and areas
- Records of soil and water inspections undertaken
- Records of testing (monitoring program results) of any water prior to discharge and quality of water discharged in the CWQMR
- Records of the release of the hold point to discharge water from the construction site to the receiving environment
- Records of the treatment of contaminated material in accordance with the SMPSAQ
- Records of the treatment of acid sulfate soils in accordance with the ASSMP
- Copies of waste classification reports
- Copies of all trucking and tipping dockets for spoil that is tipped at landfill.
- Discharge under the COS will be recorded in a Controlled Overflow Strategy Summary Report (COSSR).
- Waste Tracking Register
- Water Quality Monitoring Reports

Appendix A – Discharge Permit

Section 1: Permit Details	Permit Number
External Permit Required? Yes/No	If yes, specify external permit number:
Location (Sediment Basin No. / Chainage / GPS Coordinates):	Site Environmental Plan (SEP) number:
Proposed Start Date / Time:	Proposed Completion Date / Time:
Receiving Water Body:	

Section 2: Water Quality Record (to be completed by authorised water quality monitoring personnel only)		
Parameter	Water to be Discharged	Receiving Water
Turbidity: (Site specific correlation to be developed if NTU used)		
Total Suspended Solids (TSS<50)		
pH: (6.5-8.5)		
Oil and Grease (nonvisible)		
Comments:		

Section 3: Permit Conditions / Approval

Mandatory Permit Conditions:

- Float the foot valve to ensure it does not sit in mud at the base of the sediment basin.
- Ensure that the water discharge point is located so that it will not cause erosion and re-suspension of sediment.
- Check the discharge regularly to ensure it remains clear to visible sediment and appears clean. The person issuing this permit must test water quality in the receiving water on an hourly basis.
- Cease dewatering immediately if water quality in the receiving waterway is adversely affected or if a turbidity plume is visible.

(Hand write any additional conditions / instructions below)

I understand and accept the permit conditions detailed above.

Supervisor/Engineer/Subcontractor

Name..... Signature.....

Permit Issuer / Project Environmental Representative:	Issue Date: __/__/__
	Expiry Date: __/__/__
Name.....	
Signature.....	

Section 4: Permit Closure

I confirm all work for which this permit was issued has been completed.

Supervisor/Engineer/Subcontractor:

Name..... Signature..... Date.....

I confirm all work for which this permit was issued has been completed and verified.

Permit Issuer/Project Environment Representative:

Name..... Signature..... Date.....

Appendix B – Erosion and Sediment Control Plan

Sydney Football Stadium – Moore Park Precinct
Village & Carpark

Primary Erosion and Sediment Control Plan

May 2024 - Revision 1

Prepared for:



Prepared by:

ANDREW LITTLEWOOD

CPESC & Senior Soil Conservationist

Document Authorship Information

Project	Sydney Football Stadium – Moore Park Precinct Village & Carpark
Document Type	Management Report
Document	Erosion and Sediment Control Plan
Document Author	Andrew Littlewood – Senior Soil Conservationist
Qualification	Certified Professional in Erosion and Sediment Control (CPESC No. 5988). Certified Erosion, Sediment and Storm Water Inspector (CESSWI) No. 12101
Relevant Training	<ul style="list-style-type: none"> • SEEC and IECA (Australasia) – ‘Water Management on Construction sites’ & ‘Preparing and Reviewing Plans for Soil and Water Management’ – 2009 • University of Western Sydney and Hawkesbury Global Ltd - Certificate of Attainment in Soil and Water Management for Urban Development - 2000
Experience – Years	24 years (2000 – 2024)
Current Employment	Director & Principal - Rubicon Enviro Pty Ltd (2016-2021)
Previous Employment	Senior Soil Conservationist & CPESC – TREES Pty Ltd (2008-2016)
Previous Employment	Erosion and Sediment Control Officer - Lake Macquarie City Council (2000 – 2007)
Professional Affiliations	Member of International Erosion Control Association (Australasia)

Document Status

Rev No.	Date	Revision Description	Prepared by	Revision Details	Reviewed	
					Name	Date
0	03/05/2024	Revision 0	A Littlewood	Initial Draft		
1	17/05/2024	Revision 1	A Littlewood	<ul style="list-style-type: none"> • Revised PESCP for Stage 2. • Updated Appendix B 		

© Rubicon Enviro Pty Ltd – (2024)

This document is subject to copyright and apart from any use permitted under the Copyright Act 1968, no part may be reproduced by any process, nor may any other exclusive right be exercised, without the permission of Rubicon Enviro Pty Ltd.

This document and the information herein has been prepared by Rubicon Enviro Pty Ltd solely for the use of the authorised recipient. This document must not be reproduced, altered, disseminated, electronically stored, or transmitted, in whole or in part, for any purpose other than for which it was intended.

Rubicon Enviro Pty Ltd makes no representation, undertakes any duty, or accepts any responsibility to third parties who elect to rely upon this document, or the information contained therein.

Contents

1	Introduction	6
2.	Purpose	6
3.	Scope	6
4.	Objectives	6
5.	Performance Criteria	6
6.	Guidelines, Standards and Procedures	7
7.	Environmental Planning	8
7.1	Construction Activities	8
7.2	Impacts	8
7.3	'Blue Book' receiving waters classification	9
7.4	Key Management Strategies	9
7.5	Preparation of Progressive Erosion and Sediment Control Plans (PESCP's)	9
7.6	Erosion and Sediment Control Training for Site Personnel	10
7.7	Inspection and Maintenance	11
8.	Erosion Control Measures and Sediment Control Methods	11
9	Soil & Water Management Activities & Controls	15

Appendices

Appendix A:	Site Characteristics & Revised Universal Soil Loss Equation (RUSLE) Assessment
Appendix B:	RUSLE Catchment Assessment & Sediment Basin Calculations
Appendix C:	Sediment Basin Management & Site Dewatering Procedure
Appendix D:	Site Dewatering Discharge Record
Appendix E:	Wet Weather Contingency Procedure
Appendix F:	Progressive Erosion & Sediment Control Plans
Appendix G:	Standard drawings

Glossary & Abbreviations

Abbreviations	Expanded text
ANZECC	Australian and New Zealand Environment and Conservation Council
ASS	Acid Sulfate Soil
AWS	Automatic Weather Station
BOM	Bureau of Meteorology
Construction	Includes all activities required to construct the CSSI as defined in the Project Description described in the documents listed in Condition A1, including commissioning trials of equipment and temporary use of any part of the CSSI, but excludes Low Impact Work which is carried out or completed prior to approval of the CEMP and works approved under a Site Establishment Management Plan.
CSWMP	Construction Soil and Water Management Sub-plan
DCCEEW	Department of Climate Change, Energy the Environment and Water
DECC	Former NSW Department of Environment & Climate Change
DPI - Fisheries	NSW Department of Primary Industries - Fisheries
DPHI	NSW Department of Planning, Housing and Infrastructure (formerly NSW Department of Planning, Industry and Environment)
EC	Electrical conductivity
EMS	Environmental Management System
Environmental aspect	Defined by AS/NZS ISO 14001:2004 as an element of an organisation's activities, products or services that can interact with the environment.
Environmental impact	Defined by AS/NZS ISO 14001:2004 as any change to the environment, whether adverse or beneficial, wholly, or partially resulting from an organisation's environmental aspects.
Environmental incident	An unexpected event that has, or has the potential to, cause harm to the environment and requires some action to minimise the impact or restore the environment.
Environmental objective	Defined by AS/NZS ISO 14001:2004 as an overall environmental goal, consistent with the environmental policy, that an organisation sets itself to achieve.
Environmental target	Defined by AS/NZS ISO 14001:2004 as a detailed performance requirement, applicable to the organisation or parts thereof, that arises from the environmental objectives and that needs to be set and met in order to achieve those objectives.
EPA	NSW Environment Protection Authority
EP&A Act	Environmental Planning and Assessment Act 1979
ESCP	Primary Erosion and Sediment Control Plan

Abbreviations	Expanded text
EWMS	Environmental Work Method Statements
OFM	Organic Fibre Mulches
PASS	Potential Acid Sulfate Soil
PESCP	Progressive Erosion and Sediment Control Plan
PIRMP	Pollution Incident Response Management Plan
POEO Act	<i>Protection of the Environment Operations Act 1997</i>
RECP	Rolled Erosion Control Products
RUSLE	Revised Universal Soil Loss Equation
MSDS	Material Safety Data Sheet
SEPP	NSW State Environmental Planning Policy
SSD	State Significant Development
TfNSW	Transport for New South Wales

Primary Erosion & Sediment Control Plan

Sydney Football Stadium – Moore Park Precinct Village & Carpark

1 Introduction

This Primary Erosion and Sediment Control Plan (Sub-plan) has been prepared as Appendix B of the approved Construction Soil and Water Management Sub-plan, prepared by Besix Watpac – February 2024, and to address the Conditions of Development Consent for the State Significant Development (SSD No. 9835), specifically Conditions B25 C27, C33, C40 and C44.

The Sub-plan has been prepared to reduce the potential for risk of environmental impacts caused by erosion and sedimentation associated with project activities.

2 Purpose

The purpose of this Sub-plan is to outline the planning, methodologies, techniques, and monitoring to minimise the potential environmental impacts of erosion and sedimentation arising from the Project construction activities.

3 Scope

The scope of the Primary ESCP will:

- Provide a strategy and framework for construction to be planned, implemented, and maintained to mitigate any adverse environmental impacts,
- Propose control measures and management procedures to be implemented during construction, to avoid or minimise potential adverse impacts to soils, surface water and groundwater.

This Primary ESCP has been prepared in accordance with the requirements of the 'Blue Book' being a collective of:

- Managing Urban Stormwater: Soils and Construction 4th Edition Volume 1 – Landcom, reprinted 2006,
- Volume 2A: Installation of Services – NSW Department of Environment & Climate Change (DECC), 2007,

4 Objectives

The key objectives of the Primary ESCP are to:

- Identify potential impacts to soil and water quality such as erosion and sedimentation arising from construction activities,
- Outline the soil and water management strategy for the construction phase of the development,
- Promote the adoption of sound principles and criteria for planning and implementation of erosion and sediment controls,
- Ensure the design and construction of controls is undertaken in accordance with the relevant guidelines,
- Minimise the adverse risks to soils and water by detailing mitigation measures and strategies,
- Provide an outline of a monitoring, inspection, and reporting framework for the ongoing assessment of adherence to the ESCP.

5 Performance Criteria

The performance criteria for the ESCP are to:

- Limit potential for adverse environmental impacts on downstream waterways, riparian zones, and other identified sensitive areas,
- Minimise the risk and subsequent occurrence of erosion and sedimentation, to mitigate the impacts on project areas, sensitive areas, and downstream environments,
- Prevent the occurrence of pollution incidents causing environmental harm,

Primary Erosion & Sediment Control Plan

Sydney Football Stadium – Moore Park Precinct Village & Carpark

- Maintain existing downstream waterway attributes and water quality parameters,
- Manage erosion and sedimentation with sound management practices of effective planning and formation of relevant controls,
- Ensure compliance with legislative & regulatory requirements, and to maintain liaison and communication with statutory authorities and/or delegates.

6. Guidelines, Standards and Procedures

Name of Document/Publication	Author	Published
Acid Sulfate Soil Manual	ASSMAC	1998
Acid Sulfate Soil and Rock	Victorian EPA	2009
Approved Methods for the Sampling and Analysis of Water Pollutants in NSW	NSW EPA	2004
Australian and New Zealand Guidelines for Fresh and Marine Water Quality	ANZECC and ARMCANZ	2000
Bunding & Spill Management	NSW DEC	1997
Code of Practice for Water Management – Road Development and Management	NSW RTA	1999
Controlled Activities on Waterfront Land – Guidelines for instream works on waterfront land	NSW DPI	2012
Environmental Best Management Practice Guideline for Concreting Contractors	NSW DEC	2004
Guidelines for the Management of Acid Sulphate materials: Acid Sulphate Soils, Acid Sulphate Rock and Monosulphidic Black Ooze	NSW RTA	2005
Guideline for Construction Water Quality Monitoring	NSW RMS	-
Guideline for Environmental Management - Spraying Bituminous Materials	VIC EPA	2002
Guideline for Handling Liquids	NSW DECCW	2007
Managing Urban Stormwater ('Blue Book'): Soils and Construction Volume 1, 4 th Edition	NSW Landcom	2004
'Blue Book' - Volume 2A Installation of Services	NSW DECCW	2008
'Blue Book' - Volume 2D Main Roads Construction	NSW DECCW	2008
Management of Tannins from Vegetation Mulch	NSW RMS	2012
Noxious and environmental weed control handbook	NSW DPI	2014
Pacific Hwy Practice Note for Dewatering & Dewatering Guideline	NSW RMS	-
Policy and Guidelines for Fish Friendly Waterway Crossings	NSW Fisheries	2003
Policy and Guidelines for Fish Habitat Conservation and Management	NSW Fisheries	2013
RMS Dewatering Guideline	NSW RMS	-
RMS Guideline for Batter Surface Stabilisation using vegetation	NSW RMS	2015
RMS Technical Guideline - Temporary stormwater drainage for road construction	NSW RMS	2011
RTA Stockpile Site Management Procedure	NSW RTA	2001
Table Drains - Erosion Control Guideline	Brisbane City Council	2001
Technical Guideline - Temporary stormwater drainage for road construction	NSW RMS	2011
'Why do Fish Need to Cross the Road? Fish Passage Requirements for Waterway Crossings'	NSW Fisheries	2003

Primary Erosion & Sediment Control Plan

Sydney Football Stadium – Moore Park Precinct Village & Carpark

7. Environmental Planning

Erosion and sediment control planning is based on the principle that preventing erosion where possible provides the best environmental outcomes, is more economical, and effective than controlling the capture of sediment. This is a significant goal, given the Project topography, drainage patterns and soils that have a significant proportion of sodic soils that are highly erodible.

7.1 Construction Activities

The scope and anticipated duration of the Project works present risks of environmental impacts to the environment. Key aspects of the project that could result in adverse impacts to soils and water include:

- Installation of preliminary erosion and sediment controls and establishment of off-site water diversions,
- Establishment of compounds, exclusion zones, stockpile and ancillary areas, and contaminated soils treatment area/s,
- Vegetation clearing, grubbing and topsoil stripping,
- Demolition and removal of structures, pavement & kerbing, and drainage structures,
- Bulk earthworks,
- Relocation of services/utilities,
- Construction of internal haulage and access routes,
- Culvert and drainage works, including Gross Pollutant Traps (GPTs),
- Material stockpiling,
- Concreting works for utilities, pavements and drainage including washout facilities,
- Asphalt pavement placement activities,
- Water use/extraction,
- Compound operation including fuel and chemical storage, refuelling and chemical handling,
- Noxious weed treatment including herbicide spraying,
- Topsoil replacement, stabilisation, revegetation, and landscaping,

Refer also to Section 8 of the Project CSWMP.

7.2 Impacts

The possible impacts on soil and water from the activities described include:

- Unnecessary disturbance of existing areas outside the Project footprint,
- Erosion of soils that degrade the water quality of runoff to downstream receivers, dependant flora and fauna, and sensitive areas,
- Degraded soil or water quality from exposure to contaminated soils or ASS material, or run-off from these soils,
- Contamination of soils, and surface and groundwater from accidental spills or oil leaks,
- Disturbance or degradation of groundwater aquifers,
- Litter and gross pollutants from construction activities,
- Atmospheric dust pollution affecting air quality of areas surrounding the Project.

Primary Erosion & Sediment Control Plan

Sydney Football Stadium – Moore Park Precinct Village & Carpark

7.3 'Blue Book' receiving waters classification

The recommended minimum design criteria for temporary erosion and sediment control measures are based upon an assessment of the sensitivity of receiving environments. In accordance with the CSWMP assessment, the attributes of the receiving waters in the vicinity of the Project have been assessed as 'sensitive' in accordance with Blue Book Volume 1- Sect. 6.3.4 – (f) & Volume 2D – Table 6.1.

7.4 Key Management Strategies

The following list outlines the Key Management Strategies that will be implemented to mitigate potential erosion and sediment impacts:

- Specialist expertise and advice will be sought from an accredited Project Soil Conservationist in regard to the broad spectrum of erosion and sediment control issues, including but not limited to site establishment, temporary access routes, off-site water diversion, on-site drainage, sediment control construction/operation/decommissioning, soil handling and storage, water management, stabilisation, and rehabilitation/revegetation of Project areas,
- Implementation of structured erosion and sediment control training program for all relevant site personnel in the form of inductions, toolbox talks and workshops/training presentations,
- Minimising the extent and duration of construction disturbance,
- Control and diversion of off-site water flows around or across site,
- Control and diversion of on-site flows to installed sediment controls and sediment basins,
- Conservation of topsoils for site rehabilitation and revegetation,
- Implementation of progressive erosion methods & techniques throughout various work stages,
- Construction and management of suitable sediment controls including sediment filters, traps, and sumps,
- A thorough inspection and maintenance program to monitor, record and schedule actions for maintenance and upgrades of controls, rectification works, and sediment removal and handling,
- Establishing a procedure to monitor forecast weather events and implementing response plans for significant wind or rainfall events and flooding,
- Timely and progressive stabilisation of disturbed areas prior to final landscaping.
- Monitoring stabilisation measures and promoting prompt & effective revegetation and permanent stabilisation.

7.5 Preparation of Progressive Erosion and Sediment Control Plans (PESCP's)

This ESCP will be supplemented with Progressive Erosion and Sediment Control Plans (PESCP's) prepared as required for the relevant work areas. The PESCP's illustrate the strategy for erosion and sediment control and provides detail on structures and controls to be implemented in concert with construction activities. The PESCP's will outline structural and non-structural measures to:

- Intercept and divert clean water runoff around worksites,
- Prevent erosion,
- Limit the movement of sediment,
- Remove or filter sediment from runoff,
- Detain or control the discharge of runoff from site,
- Promote timely rehabilitation or stabilisation of disturbed areas.

Primary Erosion & Sediment Control Plan

Sydney Football Stadium – Moore Park Precinct Village & Carpark

There are a number of control measure options available for selection and use (See Table 8 below). The selection of controls will be in accordance with sound management practices to achieve the desired outcomes.

The PESCP's will be revised as necessary to address changes in the site conditions and nature of works. The PESCP's will be formulated in conjunction with construction personnel prior to the commencement of specific onsite activities. The plans will be prepared to manage the various works or construction stages such as:

- Clearing, grubbing and topsoil stripping,
- Compound, access, stockpile operations, and construction facilities,
- Bulk earthworks for road formation, drainage, services, etc,
- Major off-site and on-site water drainage works or structures such as diversions, drains and treatment/sediment basins,
- Construction activities such as paving, kerbing/guttering, stormwater drainage and outlets, etc,
- Stabilisation of disturbed areas, access and works areas, and perimeter areas,
- Decommissioning of temporary erosion and sediment controls.

The formulation of Environmental Work Method Statements (EWMS) will be sub-ordinate to the requirements of the primary ESCP, supplement the PESCP's, and will outline methods and strategies for works in critical areas such as clearing & grubbing, topsoil stripping & earthworks, works around watercourses & culvert works, construction & operation of sediment basins, drainage works, dewatering, and asphalt batch plant operation.

7.6 Erosion and Sediment Control Training for Site Personnel

Prior to the commencement of onsite activities, all site personnel will be instructed to observe site constraints and be made aware of environmental controls, in particular:

- Avoidance of disturbing or damaging 'No-Go' zones,
- Effects of erosion and sedimentation and off-site or downstream impacts,
- Environmental legislation, responsibilities, and 'due diligence,'
- Correct establishment and maintenance of erosion and sediment controls,
- 'End-of-day' site maintenance, emergency procedures, and spill response,
- Personnel to monitor, review and improve controls as appropriate.

Key construction personnel would undertake additional environmental training including a specific training session for erosion and sediment control addressing:

- Environmental impacts,
- Relevant legislation,
- Principles and techniques of erosion and sediment control,
- Preparation of PESCP's,

The structure and content of the Erosion and Sediment Control training would be developed in conjunction with Project management and construction personnel.

Primary Erosion & Sediment Control Plan

Sydney Football Stadium – Moore Park Precinct Village & Carpark

7.7 Inspection and Maintenance

A self-auditing program will be established for erosion and sediment control based on a check sheet developed for the site. A site inspection using the developed check sheet will be undertaken by relevant Project personnel:

- At least weekly,
- Immediately before extended site shut down,
- Following rainfall events greater than 10 mm over 24 hours, or prolonged rainfall events:
 - as soon as practicable but within 3 hours (during normal work hours and days)
 - or within 24 hours (outside normal work hours and days, including industry rostered days off and public holidays).

The self-audit will include:

- Noting the condition of installed erosion and sediment controls onsite,
- Detailing maintenance requirements (if any) for installed erosion and sediment controls,
- Recording the volumes of sediment removed from sediment controls and sediment traps, where applicable,
- Recording the location to where extracted sediments are disposed.

8. Erosion Control Measures and Sediment Control Methods

The formulation of the ESCP assumes that controls will generally be installed in the following progression:

- Installation of preliminary erosion and sediment controls and exclusion fencing to nominated areas of initial works and establishing exclusion zones,
- Establishing any temporary machinery access points in addition to those existing
- Identification and treatment or removal of significant weed outbreaks within the initial clearing zones,
- Installation of stabilised site access, site compound and facilities,
- Forming temporary drains or banks to maximise diversion of off-site flows away from works area to watercourses, existing drainage lines or to temporary drainage diversion structures,
- Construction of on-site water diversion drains or banks to direct runoff to the installed sediment controls,
- Installation of diversion drains/banks upslope and sediment controls down slope of proposed topsoil and spoil stockpile areas,
- Progressively strip and stockpile topsoil necessary for rehabilitation, with remainder removed from site or stabilised in a suitable site area,
- Bulk earthworks such as cut excavations, filling, batters, and engineered formation are controlled with a suite of erosion controls such as exclusion bunding, surface stabilisation treatments, trench stops, batter berms/chutes, contour banks, check dams, etc.

Primary Erosion & Sediment Control Plan

Sydney Football Stadium – Moore Park Precinct Village & Carpark

- Drainage and run-off from site areas directed to adequately designed and constructed sediment controls with regular maintenance and repair as required,
- Completed areas are progressively stabilised as soon as practical with emphasis on critical areas such as drainage outlets, batters, etc.,
- Sediment controls are to be maintained until adequate soil surface protection levels (>70% ground cover) are achieved in at least 90% of the surface area of the catchment.

The erosion and sediment control measures required for Project areas during the various construction areas will be determined by reference to the guidance and measures detailed in Appendix D of the 'Blue Book' Volume 2A: Installation of Services – (DECC), 2007. Commonly employed methods and techniques that may be utilised on the Project are detailed in the following table:

Table 8

Erosion Control – Raindrop Impact	
Situation	Control measure or method
Soil surface protection - Vegetation	<ul style="list-style-type: none"> • Temporary vegetation (cover crop only) • Permanent vegetation – introduced (exotic) pasture species or native (endemic) species
Soil surface protection - Batter protection	<ul style="list-style-type: none"> • Organic rolled erosion control products (RECP's) such as jute mesh, jute mat, coir fibre blankets • Non-organic RECP's such as non-woven geotextile membrane or heavy grade plastic sheeting. • Mulched, site generated vegetation
Soil surface protection - Mulching	<ul style="list-style-type: none"> • Hydromulch or hydraulic bonded-fibre matrix • Straw mulching with bitumen tack • Mulched, site generated vegetation • Brush-matting • Rock or gravel mulch
Soil surface protection - Surface roughening	<ul style="list-style-type: none"> • Roughening dormant areas parallel to contour • Contour ripping or scarifying • Machinery 'track walking' perpendicular to the contour
Soil surface protection - geobinders	<ul style="list-style-type: none"> • Organic tackifiers • Co-polymer emulsions • Bitumen emulsion • Cementitious products
Erosion control - Concentrated Water Flow	
Up-slope diversions	<ul style="list-style-type: none"> • Excavated channel-type bank • Back push-type bank or windrow • Catch drains • Batter lip berm
Mid-slope diversions	<ul style="list-style-type: none"> • Berms and benches • Temporary diversions (at cut/fill line) • Cross banks

Primary Erosion & Sediment Control Plan

Sydney Football Stadium – Moore Park Precinct Village & Carpark

Situation	Control measure or method
Soft armour channels	<ul style="list-style-type: none"> • Trapezoidal or parabolic shape design drain cross sections • Organic rolled erosion control products (RECP's) such as jute mesh, jute mat, coir fibre blankets • Non-organic RECP's such as non-woven geotextile membrane or heavy grade plastic sheeting • Organic tackifiers & co-polymer emulsions • Bitumen emulsion • Hydro mulch • Standard or reinforced turf
Hard armour channels	<ul style="list-style-type: none"> • Loose rock – hard quarry rock or reclaimed river rock • Rock-filled wire mattresses • Grouted rock • Cast in-situ concrete • Underlays utilising heavy grade plastic lining or geotextile lining
In-stream works	<ul style="list-style-type: none"> • Temporary coffer dams and control bunds • Temporary lined channels • Stabilised working platforms
Check dams	<ul style="list-style-type: none"> • Stacked rock • Sandbags and aggregate filter bags • Geotextile covered straw bales • Coir logs
Batter drainage	<ul style="list-style-type: none"> • Geotextile lined or heavy grade plastic chutes • Pipes and Half pipes • Loose-rock rip rap • Concrete (pre-cast or on-site) • Rock-filled wire mattresses
Grade control structures and flumes	<ul style="list-style-type: none"> • Geotextile lined or heavy grade plastic chutes • Pipes and Half pipes • Concrete chutes • Loose-rock rip rap • Gully pits and field inlets • Sandbag drop structures • Rock-filled wire gabions and mattress structures
Outlet dissipation structures	<ul style="list-style-type: none"> • Loose-rock rip-rap apron diffusers • Rock-filled wire mattresses • Pinned geotextile aprons • Level spreaders
Revetments and retaining walls	<ul style="list-style-type: none"> • Rip rap • Rock-filled wire gabions and mattresses

Primary Erosion & Sediment Control Plan

Sydney Football Stadium – Moore Park Precinct Village & Carpark

Sediment control - Sheet Flows	
Situation	<ul style="list-style-type: none"> Control measure or method
Vegetative filters	<ul style="list-style-type: none"> Stripped topsoil and surface vegetation windrowed parallel to the contour Compacted mulch berms with geotextile lined spillways Designated & controlled vegetated filter areas within the Project boundaries Turf strips
Sediment barriers/filters	<ul style="list-style-type: none"> Sediment fencing Topsoil berms stabilised with vegetation or geotextile with filter outlets at intervals Compacted mulch berms and sediment traps with geotextile lined spillways Excavated and geotextile lined sediment traps Geotextile covered rock or gravel windrows Coir logs
Site exit points	<ul style="list-style-type: none"> Shaker grids with paved or rock aprons and sediment sumps Wheel wash equipment and designated/controlled areas
Sediment control - Concentrated Flows	
Sediment curtains / turbidity barriers	<ul style="list-style-type: none"> Geotextile turbidity curtain & floating boom Sediment fence Temporary coffer dams
Sediment traps	<ul style="list-style-type: none"> Sediment basins Stacked rock with geotextile Excavated and geotextile lined sediment traps Straw bale or sandbag structures Gully pit, field inlet and kerb inlet traps

Primary Erosion & Sediment Control Plan

Sydney Football Stadium – Moore Park Precinct Village & Carpark

9 Soil & Water Management Activities & Controls

The following table outlines the environmental management and mitigation measures proposed to be implemented, together with responsibilities and frequency of actions:

Table 9

1. Planning, permits & personnel		
Environmental Management Controls	Person Responsible	Timing / Frequency
1. All necessary licences, permits and approvals required by legislation will be obtained prior to works commencing.	Project Manager / Supervisor / Environmental Site Representative	Duration
2. Copies of any relevant licences, permits and approvals will be kept on site for inspection upon request or otherwise, as required.	Project Manager / Supervisor / Environmental Site Representative	Site establishment
3. All works and site activities will comply with the explicit requirements of any relevant licence, permit or approval.	Project Manager / Supervisor / Environmental Site Representative	Duration
4. Recordings and data from site inspections, testing, audits, and monitoring will be retained, with associated documentation maintained to demonstrate remedial action/s have occurred.	Project Manager / Supervisor / Environmental Site Representative	Duration
5. Erosion and sediment control planning is required prior to the commencement of works. The approved CEMP & CSWMP is supplemented by concept Progressive Erosion & Sediment Control Plans (PESCP's) which have been developed in accordance with the requirements of 'Soils and Construction: Managing Urban Stormwater' 4 th Edition. - Landcom 2006.	Project Manager / Supervisor / Environmental Site Representative	Site establishment & duration
6. The CEMP & CSWMP & construction PESCP's may be supplemented by site-specific Environmental Management Plans (EMP's) which would be developed in response to a significant environmental issue emerging. The EMP's would outline the relevant environmental risks and issues, mitigation of potential risks, and detail strategies for remediation and/or management.	Project Manager / Supervisor / Environmental Site Representative	Site establishment & duration
7. The induction of employees and contractors to include a component promoting environmental awareness, legislative requirements & penalties, and basic erosion and sediment control tasks	Project Manager / Supervisor / Environmental Site Representative	Site establishment & duration
8. Toolbox talks will regularly focus on specific works, associated risks, potential impacts, and mitigation measures. Specific erosion and sediment control awareness training and workshops will be undertaken by personnel with direct involvement with erosion and sediment control.	Supervisor / Environmental Site Representative	Site establishment & duration
9. Catchment risk assessments are to be undertaken for the implementation of staging for catchment clearing to ensure adequate resources are available to implement controls.	Supervisor / Environmental Site Representative	Site establishment

Primary Erosion & Sediment Control Plan

Sydney Football Stadium – Moore Park Precinct Village & Carpark

Environmental Management Controls	Person Responsible	Timing / Frequency
10. Promote planning for seasonal restrictions for high-risk areas and/or activities ((i.e., late summer/autumn rainfall events for culvert works or cold winter temperatures affecting revegetation)	Project Manager / Supervisor / Environmental Site Representative	Site establishment & duration
2. Clearing, site establishment, topsoil stripping & stockpiling		
1. Exclusion areas ('No Go' zones) to be identified, delineated where practical, and personnel instructed to avoid disturbance in these areas.	Supervisor / Environmental Site Representative	Site establishment
2. Temporary fencing or barricading such as parawebbing or perimeter tape is to be utilised on the cleared perimeter with accompanying signage as required. Site inductions and toolbox meetings should include the importance of observing exclusion zones, particularly in areas near any identified sensitive area.	Supervisor / Environmental Site Representative	Site establishment
3. Areas of proposed works with identified noxious weed infestations to be treated with appropriate herbicide, in accordance with product directions. The weed treatment will occur in sufficient time prior to disturbance to ensure complete 'die back' prior to topsoil handling.	Supervisor / Environmental Site Representative	Site establishment
4. In areas requiring weed control, spray drift will be mitigated by conducting spraying activities in calm weather and application by hand sprayer unit where practical.	Supervisor / Environmental Site Representative	Site establishment
5. The extent of earthworks and formation stripping will be demarcated to the footprint necessary for the proposed works. Disturbance outside the earthwork's footprint will be limited to necessary operations such as stockpiling, lay downs, etc.	Supervisor / Environmental Site Representative	Site establishment & duration
6. Early establishment of suitable stockpiling and processing areas to reduce unnecessary soil disturbance from double handling of soil by machinery in the early works phase.	Supervisor / Environmental Site Representative	Site establishment & duration
7. Construct erosion resistant access routes, site access/egress points, and compound roads to be formed and stabilised as early works. Car parking areas and frequently utilised areas should be stabilised (e.g., geotextile with asphaltic millings, rock aggregate overlay, bitumen chip seal or similar) to prevent soil churning, where required. Any rock or aggregate required for vehicle access should be clean and free from soil or other contaminants.	Supervisor / Environmental Site Representative	Site establishment & duration
8. Vegetation will be progressively cleared to minimise disturbance by area and duration. Cleared vegetation to be windrowed parallel to the contour until mulching/removal to control flows across cleared areas	Supervisor / Environmental Site Representative	Site establishment
9. During the process of topsoil stripping, the soils should be handled when it is not wet or dry, but sufficiently moist to avoid damage to the soil structure.	Supervisor / Environmental Site Representative	Site establishment

Primary Erosion & Sediment Control Plan

Sydney Football Stadium – Moore Park Precinct Village & Carpark

Environmental Management Controls	Person Responsible	Timing / Frequency
10. Temporary drains, banks or diversions are to be formed and stabilised to divert concentrated 'clean' flows around disturbed works areas.	Supervisor / Environmental Site Representative	Site establishment & duration
11. The installation of preliminary sediment controls such as perimeter sediment fencing, excavated sediment traps, check dams, coir log/straw bale filters, etc, will be implemented prior to disturbance within the catchment.	Supervisor / Environmental Site Representative	Site establishment
12. Strip any viable topsoil in the required locations and stockpile locally where possible. The topsoil will be handled and stored in the correct manner necessary for successful rehabilitation.	Supervisor / Environmental Site Representative	Site establishment & duration
13. Any viable stripped topsoil to be stored in stockpiles less than two metres in height where possible. The stockpile locations are to avoid concentrated surface flows or areas subject to inundation during wet weather.	Supervisor / Environmental Site Representative	Site establishment & duration
14. The long-term soil stockpile locations are to be located 5 metres away from concentrated water flows and at least 10m from any watercourse. The stockpiles will not be established in areas subject to concentrated surface flows, waterlogging or prolonged inundation during wet weather.	Supervisor / Environmental Site Representative	Site establishment & duration
15. Stockpiles should be stabilised if they are to remain in place for more than 20 days. Rolled Erosion Control Products (RECP's such as geotextile, jute mesh, coco fibre mat, etc) or soil binders can be used on smaller stockpiles, however, larger stockpiles should be formed into crowned structures to minimise erosion and be subsequently stabilised with cover crop seeding or applied geobinders. Plastic covers should only be utilised for short term cover for wind or storm protection.	Supervisor / Environmental Site Representative	Site establishment & duration
16. The use of existing, available materials on-site (i.e., soils, rock, etc) to be salvaged and stored where it can be utilised for temporary or permanent works (where practical) to reduce import requirements.	Supervisor / Environmental Site Representative	Site establishment & duration
17. Where practical, cut earthworks should be staged to ensure lift well basements and basement storage tanks are progressively excavated to control dirty water within the excavation	Supervisor / Environmental Site Representative	Site establishment & duration
18. Subgrade excavations and engineered fill formations at risk of temporary inundation during rain events may be stabilised with moisture-repelling soil binders.	Supervisor / Environmental Site Representative	Duration
19. Access to the works area, and movements on the site during construction will be limited to the defined access and project areas, where possible. Minimise vehicle movements & speed on unsealed areas and access tracks.	Supervisor / Environmental Site Representative	Duration
20. Earthworks and hauling, and vehicular movements to be limited in wet conditions.	Supervisor / Environmental Site Representative	Duration

Primary Erosion & Sediment Control Plan

Sydney Football Stadium – Moore Park Precinct Village & Carpark

Environmental Management Controls	Person Responsible	Timing / Frequency
21. Appropriate sediment tracking controls such as an aggregate/geotextile apron, shaker grid, etc will be installed at exit points from the site.	Supervisor / Environmental Site Representative	Duration
22. The adjoining local road network to be regularly monitored for tracked sediments with affected areas cleaned as soon as possible in a safe manner.	Supervisor / Environmental Site Representative	Duration
23. Vehicles transporting bulk materials such as soils and fill are to correctly cover loads to prevent loss of load and/or dust generation on public roads.	Supervisor / Environmental Site Representative	Duration
24. Imported quarry products and fill materials required for construction are to be clean, and free of contaminants (i.e.. weeds, waste, liquids, etc).	Supervisor / Environmental Site Representative	Duration
25. Water carts are to regularly spray access tracks, works areas, & temporary stockpiles, during dry weather conditions.	Supervisor / Environmental Site Representative	Duration
26. Bunded or controlled areas for refuelling, material stockpiling, (and contaminated soil treatment area if required) are to be formed prior to commencement of those works in the relevant risk areas.	Supervisor / Environmental Site Representative	Site establishment & duration
27. Personnel to ensure visual dust monitoring is maintained during works, and dust suppression is undertaken regularly.	Supervisor / Environmental Site Representative	Duration
28. Minimise earthworks, soil handling and general disturbance during periods of strong and/or gusty winds.	Supervisor / Environmental Site Representative	Duration
29. Apply water sprays for dust suppression where works, soil handling and/or potentially contaminated soils are generating dust.	Supervisor / Environmental Site Representative	Duration
3. Drainage and water management		
1. Works in high-risk zones are to be conducted in low rainfall periods, supported by positive 3-day weather forecasts for the anticipated scope of works.	Supervisor / Environmental Site Representative	Duration
2. The formation and stabilisation of permanent drains will be prioritised to minimise the requirement for temporary drains. Any temporary drain designs to be assessed to ensure adequate capacity and cross-sectional volumes are achieved.	Supervisor / Environmental Site Representative	Duration
3. Permanent storm water drains, and outlet structures will be stabilised as soon as possible following completion.	Supervisor / Environmental Site Representative	Duration
4. Immediately line any constructed off-site water diversion with appropriate RECP's, OFM's and/or geobinders. Temporary spillways and associated structures to be suitably stabilised for the volume and turbulence of flows.	Supervisor / Environmental Site Representative	Duration
5. Temporary 'dirty' water drainage will be adjusted progressively to maximise flows to sediment filters and traps.	Supervisor / Environmental Site Representative	Duration

Primary Erosion & Sediment Control Plan

Sydney Football Stadium – Moore Park Precinct Village & Carpark

Environmental Management Controls	Person Responsible	Timing / Frequency
6. Check dams are to be constructed from geotextile/aggregate bags, sandbags, staked coir logs/straw bales or loose rock formations to reduce flow velocities in unlined drains and other areas of concentrated flow (i.e., against diversion banks). Check dams are to be installed at the required intervals in drains with the frequency of the dams increasing as the grade increases.	Supervisor / Environmental Site Representative	Duration
7. Sheet flows in work areas have erosion measures such as surface roughening, scribed drains and/or contour banks to reduce slope lengths. Flows from diversions to have velocities controlled and directed to sediment controls.	Supervisor / Environmental Site Representative	Duration
8. Trenching works on grade will be controlled with methods detailed in the 'Blue Book' – Volume 2A' - Section 6	Supervisor / Environmental Site Representative	Duration
9. Flooded excavations, ponded water, etc will be extracted as required and utilised for construction purposes or treated to achieve acceptable water quality prior to discharge.	Supervisor / Environmental Site Representative	Duration
10. The use of reclaimed water will be prioritised for construction uses where possible to minimise potable water usage.	Supervisor / Environmental Site Representative	Duration
11. Flooded excavations and groundwater encountered in PASS areas or potentially contaminated areas will be pH tested and visually assessed and extracted for treatment, & subsequent discharge, or conveyed to a licensed liquid waste facility.	Supervisor / Environmental Site Representative	Duration
12. Site water that is to be discharged directly to a flow line, drain, watercourse, etc, will be tested, treated, and recorded prior to discharge.	Supervisor / Environmental Site Representative	Duration
13. Water quality should meet the following minimum criteria prior to discharge: <ul style="list-style-type: none"> • Total suspended solids (TSS) – less than 50 mg/L • pH – 6.5 to 8.5 • oil and grease – not visible and less than 10 mg/L 	Supervisor / Environmental Site Representative	Duration
14. Dewatering devices or transfer pumps will be positioned to ensure that settled sediments are not disturbed or extracted. Discharge of concentrated flows of treated water to lands will occur with diffusers or level spreaders to prevent erosion.	Supervisor / Environmental Site Representative	Duration
15. The appearance of water quality at the discharge outlet will be regularly monitored for any increase in turbidity, and dewatering suspended until acceptable water quality levels are regained	Supervisor / Environmental Site Representative	Duration
16. Adequately designed and constructed concrete washout facilities will be constructed in a suitable location away from drainage lines. Concrete wash down to occur directly into lined receptacles or formed washouts.	Supervisor / Environmental Site Representative	Duration

Primary Erosion & Sediment Control Plan

Sydney Football Stadium – Moore Park Precinct Village & Carpark

Environmental Management Controls	Person Responsible	Timing / Frequency
4. Sediment Controls		
1. Commonly used sediment control devices have construction details described in the Standard Drawings shown at Appendix G. Alternative controls or methods may be employed in certain circumstances for practicality or efficiency purposes. Alternative controls or methods must demonstrate efficacy and be in accordance with the intent and objectives of the 'Blue Book'.	Supervisor / Environmental Site Representative	Duration
2. Substitute materials may be utilised in the construction of erosion or sediment controls where functionality is not affected.	Supervisor / Environmental Site Representative	Duration
3. Sediment fencing, non-woven geotextile, or compacted mulch bunds, etc, will be installed on down slope work boundaries, down slope of stockpiles, batters, etc, to filter sheet flows.	Supervisor / Environmental Site Representative	Duration
4. Sediment filters will be formed from straw bales, aggregate & geotextile filter bags, coir logs, etc, to control concentrated on-site water flows as required	Supervisor / Environmental Site Representative	Duration
5. Excavated sediment traps may be utilised at critical locations at the toe of the contributing catchment. They will be desilted at 40% capacity and are to be dewatered prior to the onset of further rainfall.	Supervisor / Environmental Site Representative	Duration
6. The excavated sediment traps should be regarded as a secondary control, relying on retention of coarse sediment in upslope controls within the construction area.	Supervisor / Environmental Site Representative	Duration
7. Aggregate filter bags or sandbag inlet traps are to be deployed on roadside pit inlets or other inlets to the drainage system.	Supervisor / Environmental Site Representative	Duration
8. Gully pit inlets will be protected with filter inlet controls formed from sediment fence, filter bags, straw bales & geotextile, coir logs, etc.	Supervisor / Environmental Site Representative	Duration
9. The sediment captured by control devices is to be removed when 40% of capacity is reached. Regular desilting is also to maintain catchment and settling capacity, and to reduce re-entrainment of settled materials in subsequent rain events.	Supervisor / Environmental Site Representative	Duration
5. Soil Contamination		
1. Excavation of sub-soils to be inspected and monitored as works proceeds, to identify potential contamination. Any potentially contaminated soils to be stripped or excavated separately and transported directly to the designated stockpile, treatment area or licensed waste facility.	Supervisor / Environmental Site Representative	Duration
2. Potentially contaminated soils are to be stored within an appropriately bunded area and covered with heavy grade plastic or other impermeable covers for the duration of rainfall.	Supervisor / Environmental Site Representative	Duration

Primary Erosion & Sediment Control Plan

Sydney Football Stadium – Moore Park Precinct Village & Carpark

Environmental Management Controls	Person Responsible	Timing / Frequency
3. Potentially contaminated excavated material that are required to be removed from site are to be assessed and classified in accordance with the Protection of the Environment Operations Act 1997 and ' <i>Waste Classification Guidelines: Parts 1 and 2</i> ' (DECC 2008)'.	Supervisor / Environmental Site Representative	Duration
4. Excavated soils and materials (that have been assessed, classified, treated, and re-assessed on site) will be re-used as fill material on site where appropriate.	Supervisor / Environmental Site Representative	Duration
5. Vehicles transporting potentially contaminated soils both on internal access tracks and public roads will correctly cover loads to mitigate dust generation or spillage.	Supervisor / Environmental Site Representative	Duration
6. The ground disturbance and machinery/vehicle movements in potentially contaminated areas will be minimised to essential works.	Supervisor / Environmental Site Representative	Duration
7. Earthworks, soil handling and general disturbance in potentially contaminated areas are to be avoided during periods of strong and/or gusty winds.	Supervisor / Environmental Site Representative	Duration
8. Water sprays are to be utilised to mitigate dust from contaminated soils in works areas, contaminated soil handling or temporary stockpile areas.	Supervisor / Environmental Site Representative	Duration
6. Soil & Water pollution control		
1. All waste will be handled, stored, and disposed of in accordance with the ' <i>Waste Classification Guidelines: Parts 1 and 2</i> ' (DECC 2008)'.	Supervisor / Environmental Site Representative	Duration
2. Waste construction materials such as steel, concrete, etc will be removed to an appropriate recycling facility, to a suitable location for appropriate re-use, or to a licensed waste disposal facility.	Supervisor / Environmental Site Representative	Duration
3. All putrescible, construction, and food wastes are to be immediately captured and stored correctly, prior to removal to a licensed waste facility. Putrescibles and food wastes will be removed from site on a least a weekly basis.	Supervisor / Environmental Site Representative	Duration
4. The effluent from concrete wash down is to be captured by an excavated wash out pit lined with an impervious membrane at least 50 metres away from any waterway or major drainage lines. The pit is to be protected by a diversion bund to prevent entry of site run-off that may subsequently displace alkaline water/slurry. Concrete washouts to be covered for the duration of significant or prolonged rainfall.	Supervisor / Environmental Site Representative	Duration
5. The water levels in concrete washout pits will be monitored and dewatered regularly. The water pH will be tested and treated where it is outside the parameters of pH 6.5-8.5. Where suitable pH is attained, the water can then be used site purposes.	Supervisor / Environmental Site Representative	Duration

Primary Erosion & Sediment Control Plan

Sydney Football Stadium – Moore Park Precinct Village & Carpark

Environmental Management Controls	Person Responsible	Timing / Frequency
6. The site machinery 'lay-up' area, refuelling areas and chemical storage areas are to be located outside the dripline of retained trees, at least 5 meters from native vegetation and, and 50 metres away from any waterway or major drainage lines	Supervisor / Environmental Site Representative	Duration
7. The refuelling and servicing of machinery is to be undertaken at approved premises off-site where possible. Onsite refuelling and servicing only to occur with appropriate spill control measures at hand, or where established or temporary bunded areas are available.	Supervisor / Environmental Site Representative	Duration
8. Vehicle wash down will be preferably undertaken at an appropriate area offsite, or otherwise at a designated and controlled area onsite or	Supervisor / Environmental Site Representative	Duration
9. Mobile plant, machinery and vehicles are to be regularly inspected and maintained to manufacturer's specifications.	Supervisor / Environmental Site Representative	Duration
10. Appropriate spill kits are to be always kept on site and any spillage is to be immediately cleaned up. In the event of a large or hazardous spill, contact will be made with emergency and relevant authorities, where required.	Supervisor / Environmental Site Representative	Duration
11. All site personnel will be instructed about emergency spill procedures, spill kit locations and requirements. The location of spill response kits will be established close to works or operations areas.	Supervisor / Environmental Site Representative	Duration
12. Storage of liquid construction materials (chemicals, fuels, oils, etc) will be provided in appropriately bunded areas on site to prevent leaching into soils, leaking or other transfer of material into waterways. Storage areas to be at least 50 metres from creeks and other waterways, and on slopes with a gradient of less than 10 per cent	Supervisor / Environmental Site Representative	Duration
13. Containment bunds are to be monitored regularly and captured materials removed as required to ensure bund capacity is maintained.	Supervisor / Environmental Site Representative	Duration
14. Bunded areas will satisfy requirements of the relevant Australian Standards and 'Bunding and Spill Management (DEC, 1997)'	Supervisor / Environmental Site Representative	Duration
15. The requirements of the Australian Dangerous Goods Code will be observed for storage and transport of any hazardous materials. The compatibility of all chemicals, pesticides and fuels transported and stored will be assessed to avoid potential risk from reactions, explosion, etc.	Supervisor / Environmental Site Representative	Duration
16. All chemicals, pesticides and fuel will be stored and transported in approved containers. Chemicals, pesticides and fuels are to be labelled correctly and clearly, including using approved warning symbols etc.	Supervisor / Environmental Site Representative	Duration
17. A MSDS register and will be maintained and be readily accessible on site for all hazardous chemicals transported, handled, or applied.	Supervisor / Environmental Site Representative	Duration

Primary Erosion & Sediment Control Plan

Sydney Football Stadium – Moore Park Precinct Village & Carpark

Environmental Management Controls	Person Responsible	Timing / Frequency
18. An adequate record or log of all environmentally hazardous chemicals received, used and/or disposed of will be maintained.	Supervisor / Environmental Site Representative	Duration
19. Substitution of less hazardous materials or chemicals or modifying methods of use/storage etc. will be implemented where possible.	Supervisor / Environmental Site Representative	Duration
20. The quantities of hazardous materials and chemicals stored or used will be minimised as far as practical.	Supervisor / Environmental Site Representative	Duration
21. Sensitive areas (i.e., waterways and drainage lines) will be identified before utilising or applying chemicals. Where sensitive areas are identified, appropriate guidance and relevant restrictions will be formulated for chemical use or applications.	Supervisor / Environmental Site Representative	Duration
22. The application methods and dilution ratios specified in manufacturer's directions and/or associated MSDS will be observed by personnel.	Supervisor / Environmental Site Representative	Duration
7. Stabilisation		
1. Promote efficient staging planning for early stabilisation of perimeter or completed areas. (i.e., stabilisation of permanent drains, culvert outlets, diffusers, and decommissioning of temporary controls)	Supervisor / Environmental Site Representative	Duration
2. Stabilisation of areas is to occur progressively in conjunction with the completion of earthworks.	Supervisor / Environmental Site Representative	Duration
3. Suitable design and construction techniques are to be selected for stabilisation of relevant areas such as drain linings, batter treatments, etc.	Supervisor / Environmental Site Representative	Duration
4. Completed earthworks areas will be backfilled and compacted in a staged manner as soon as possible. Adjacent disturbed areas will be suitably trimmed and stabilised as required.	Supervisor / Environmental Site Representative	Duration
5. Erosion and sediment controls are to be maintained until the relevant catchments are stabilised, re-vegetated, or sealed adequately to achieve soil surface protection factors as per the 'Blue Book', CSWMP & ESCP requirements.	Supervisor / Environmental Site Representative	Duration
6. Compounds, lay down areas and other areas of heavy construction impact to be restored to an acceptable condition. Destocking, waste removal & cleaning to be followed by scarification, topsoiling and stabilisation.	Supervisor / Environmental Site Representative	Duration
7. Any aggregate placed for vehicle access or as a work platform should be removed to a suitable location for recycling, appropriate re-use, or to a licensed waste disposal facility.	Supervisor / Environmental Site Representative	Duration
8. Any areas subject to heavy compaction and disturbance from vehicle movements and machinery will be subject to surface roughening and scarification (up to 300mm) to reduce compaction of the upper layer of soil.	Supervisor / Environmental Site Representative	Duration

Primary Erosion & Sediment Control Plan

Sydney Football Stadium – Moore Park Precinct Village & Carpark

Environmental Management Controls	Person Responsible	Timing / Frequency
9. Topsoil to be re-used locally, with batters prioritised for topsoil application and timely application of soil stabilisers where applicable.	Supervisor / Environmental Site Representative	Duration
10. Determine the cover crop mix seed blend suitable to the site & seasonal conditions to provide adequate protection until final landscaping commences.	Supervisor / Environmental Site Representative	Duration
11. Lands recently stabilised with cover crops will not be regularly watered except for initial germination or during prolonged hot & dry conditions. During milder seasons the cover crop will be monitored where received precipitation is adequate to sustain the cover crop.	Supervisor / Environmental Site Representative	Duration
12. Further application of seed may be necessary in latter stages in areas of inadequate vegetation establishment. Pedestrian and vehicular traffic will be restricted from all recently stabilised areas.	Supervisor / Environmental Site Representative	Duration

Appendix A

Site Characteristics & Revised Universal Soil Loss Equation Assessment

M1 Motorway Extension to Raymond Terrace – Heatherbrae Bypass
Primary Erosion and Sediment Control Plan

Site Characteristics Table & Revised Universal Soil Loss Equation (RUSLE) Data

Location	Sydney Football Stadium – Moore Park Precinct Village & Carpark
Construction duration	>12 months earthworks – 85 th ile adopted. (Sect. 6.3.4 – (f). Blue Book)
Erosion Hazard	Low (On slopes <9%) (Sect 4.4.1 & Figure 4.6 – Blue Book)
Soil Loss Class	Class 1 (Sect 4.4.2. & Table 4.2 – Blue Book)
Batter Restrictions	No (Sect 4.4.2 – (a) & Figure 4.8 – Blue Book)
Seasonal erosion hazard	No (Sect 4.4.2 – (c), Figure 4.9 & Table 4.3 – Blue Book)
Soil texture groups – See Typical Soil Profile diagrams below	
Tuggerah Soil Landscape - Low-Moderate Erosion Hazard landscape	tg1 – Loose speckled grey-brown loamy sand. This is grey-brown speckled sand to loamy sand with apedal single-grained structure and porous sandy fabric. It generally occurs as topsoil (A1 horizon).
	tg2 – Bleached loose sand. This is bleached sand with apedal single-grained structure and porous sandy fabric. It occurs as an A2 horizon.
	tg3 – Grey-brown mottled sand. This is mottled sand or loamy sand with apedal single-grained structure and loose sandy fabric. It occurs as subsoil in areas of poor drainage.
	tg4 – Black soft sandy organic pan. This is a black, soft, organic stained sand to loamy sand with apedal massive structure and sandy or, less commonly, earthy fabric. It often occurs as subsoil pan (B horizon) associated with tg5.
	tg5 – Brown soft sandy iron pan. This is brown soft iron-stained sand to loamy sand with apedal massive structure and sandy or less commonly earthy, fabric. It generally occurs as subsoil (B horizon) and is commonly known as coffee rock.
	tg6 – Yellow massive sand. This is yellow-orange sand to clayey sand with apedal single-grained or apedal massive structure and sandy or earthy fabric. It usually occurs as deep subsoil (B horizon).
USCS Class	Silty Sands (SM), Poorly Graded Sands (SP) to Silty Sands (SM)
Soil erodibility factor – K factor	0.016
Sediment Type	Type C
Soil hydrologic group	Group B
85 th %ile, 5-day rainfall event	38.8 mm – Sydney (Sect 6.3.4, Table 6.3a - Blue Book)
Rainfall Intensity - millimetres per hour	11.3 mm/hour (2 Year, 6 Hour storm)

M1 Motorway Extension to Raymond Terrace – Heatherbrae Bypass
 Primary Erosion and Sediment Control Plan

Site Characteristics Table & Revised Universal Soil Loss Equation (RUSLE) Data

Location	Sydney Football Stadium – Moore Park Precinct Village & Carpark
Rainfall Erosivity – R factor	2765 (Calculated from 2-year ARI, 6 Hour storm, where S=11.3mm/hour and where $R = 164.74(1.1177)^{S^{0.6444}}$ Blue Book - Appendix A2 & B)
Volumetric runoff coefficient - Cv	0.34 (Blue Book – Appendix F: Table F2)
Grade	Variable
Slope Length	80 metres adopted
LS Factor	Variable
Erosion control practice factor – P factor	1.3
Ground cover – C Factor	1.0
Sediment Storage Zone Volume design	2 months soil loss (Sect 6.3.4.- I (ii) - Blue Book)

Typical Soil Profile diagram

Tuggerah Soil Landscape

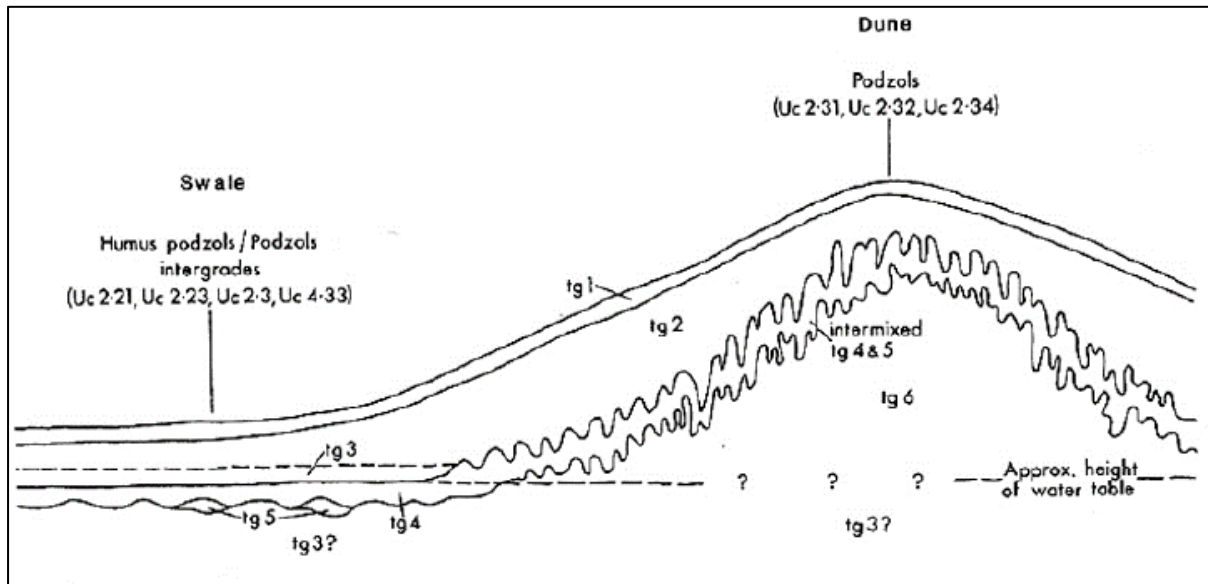

Appendix B

RUSLE Catchment Assessment & Sediment Basin Calculations

1. Erosion Hazard and Sediment Basins

Site Name: Sydney Football Stadium - Precinct Village & Carpark

Site Location: Driver Ave, Moore Park

Precinct/Stage: Calculations for Stage 1 & Stage 2

Other Details: Calculations for 5-Day Basin & 2-Day Basin

Site area	Sub-catchment or Name of Structure				Notes
	Stg 1	Stg 2	Stg 1	Stg 2	
Total catchment area (ha)	1.05	0.8	1.05	0.8	
Disturbed catchment area (ha)	0.95	0.8	0.95	0.8	

Soil analysis (enter sediment type if known, or laboratory particle size data)

Sediment Type (C, F or D) if known:	D	D	D	D			Notes
% sand (fraction 0.02 to 2.00 mm)							From Appendix C (if known)
% silt (fraction 0.002 to 0.02 mm)							Enter the percentage of each soil fraction. E.g. enter 10 for 10%
% clay (fraction finer than 0.002 mm)							
Dispersion percentage							E.g. enter 10 for dispersion of 10%
% of whole soil dispersible							See Section 6.3.3(e). Auto-calculated
Soil Texture Group	D	D	D	D			Automatic calculation from above

Rainfall data

Design rainfall depth (no of days)	5	5	2	2			
Design rainfall depth (percentile)	85	85	85	85			See Section 6.3.4 and, particularly, Table 6.3 on pages 6-24 and 6-25.
x-day, y-percentile rainfall event (mm)	38.8	38.8	22.4	22.4			
Rainfall R-factor (if known)	2765	2765	2765	2765			
IFD: 2-year, 6-hour storm (if known)	11.3	11.3	11.3	11.3			Only need to enter one or the other here

RUSLE Factors

Rainfall erosivity (R-factor)	2765	2765	2765	2765			Auto-filled from above
Soil erodibility (K-factor)	0.025	0.025	0.025	0.025			
Slope length (m)	80	80	80	80			
Slope gradient (%)	2	2	2	2			
Length/gradient (LS-factor)	0.41	0.41	0.41	0.41			RUSLE LS factor calculated for a high hill/intermittent ratio.
Erosion control practice (P-factor)	1.3	1.3	1.3	1.3	1.3	1.3	
Ground cover (C-factor)	1	1	1	1	1	1	

Sediment Basin Design Criteria (for Type D/F basins only. Leave blank for Type C basins)

Storage (soil) zone design (no of months)	2	2	2	2	2	2	Minimum is generally 2 months
Cv (Volumetric runoff coefficient)	0.51	0.51	0.42	0.42			See Table F2, page F-4 in Appendix F

Calculations and Type D/F Sediment Basin Volumes

Soil loss (t/ha/yr)	37	37	37	37			
Soil Loss Class	1	1	1	1			See Table 4.2, page 4-13
Soil loss (m ³ /ha/yr)	28	28	28	28			Conversion to cubic metres
Sediment basin storage (soil) volume (m ³)	4	4	4	4			See Sections 6.3.4(i) for calculations
Sediment basin settling (water) volume (m ³)	208	158	99	75			See Sections 6.3.4(i) for calculations
Sediment basin total volume (m ³)	212	162	103	79			

NB for sizing of Type C (coarse) sediment basins, see Worksheet 3 (if required).

Appendix C

Sediment Basin Management & Dewatering Procedure

1.1 Purpose

The purpose of the Sediment Basin Management & Dewatering Procedure (the Procedure) is to detail the actions to be taken in regard to site dewatering in general and specific measures for the construction and maintenance of sediment basins including steps to be taken prior to any discharge.

Adherence to the methodology outlined in this procedure will ensure that works are carried out in accordance with industry standard and environmental conditions.

1.2. Scope

The Procedure applies to the following works:

- Sediment basin management and maintenance; and
- Dewatering of excavations and construction water generally, and
- acid sulfate leachate ponds in the event that acid sulfate soils or rock is encountered.

1.3. Objectives

The objectives of this Procedure are to:

- Ensure all Project personnel are aware of the requirements of this procedure
- Detail personnel responsible for undertaking actions relating to sediment basin, construction dewatering and acid sulfate leachate management on the site:
- Providing a uniform, controlled methodology and clear criteria for water releases from the site:
- Implement industry standard methods for managing sediment basins and dewatering in accordance with best practice guidelines such as Managing Urban Stormwater Soils and Construction (Landcom 2004) and Acid Sulfate Soil Manual (ASSMAC 1998):
- Ensure water discharges from site are compliant with:
 - the NSW EPA Water Quality Criteria
 - Managing Urban Stormwater Soils and Construction (Landcom 2004)
 - Construction Soil and Water Management Plan,
 - Erosion and Sediment Control Plan, and
 - RMS Dewatering Guideline; and
- Comply with environmental requirements of the Project, including all legal requirements and contractual obligations.

The procedure shall ensure appropriate environmental protection measures are in place relating to sediment basins, construction water management (dewatering of excavations, culverts, etc) and management of leachate collected in ponds from acid sulfate material stockpiles.

2. Sediment Basin Construction and Management

Environmental Management Controls	Person Responsible	Timing / Frequency
Planning		
A copy of this Sediment Basin Management and Discharge Procedure will be kept on site and be made available to all relevant project personnel	Supervisor / Environmental Site Representative	Site Establishment / Duration
All relevant project personnel will be made aware of this document during the site induction and again in Toolbox Talks and targeted training sessions.	Supervisor / Environmental Site Representative	Site Establishment / Duration
Training and Awareness		
Training, instruction and equipment familiarisation for environmental personnel undertaking water quality monitoring, equipment calibration and maintenance will be the responsibility of the Environment Manager/ Environmental Site Representative. This will be completed prior to the initial use of equipment or as new equipment arrives on site.	Environmental Site Representative	Site Establishment / Duration
Training sessions will be conducted with Supervisors, Foreman, and Environmental Work Crew and relevant personnel. The training will address <ul style="list-style-type: none"> • Construction of Sediment Basins • Preliminary post-rainfall inspections • Testing and recording • Treatment methods and recording • Details of the Water Discharge Permit • Dewatering requirements, methods, and recording • Maintenance requirements, methods, and recording • Storage, Handling and Application of Flocculants 	Supervisor / Environmental Site Representative	Site Establishment / Duration
Any personnel that are responsible for monitoring pumps during dewatering activities, and that have not undertaken training described above, will undertake a specific toolbox talk to ensure awareness of requirements.	Supervisor / Environmental Site Representative	Site Establishment / Duration
Construction of Sediment Basins		
Refer to the relevant PESCPs for the location of the sediment basin/s.	Supervisor / Environmental Site Representative	Site Establishment / Duration
The location and design criteria (volume – length, width & depth) for the sediment basin/s will be outlined in the relevant PESCP. The following criteria are to be met: <ul style="list-style-type: none"> • All requirements of Landcom's - Managing Urban Stormwater: Soils and Construction Volume 1 (the Blue Book). Refer to Section 6.3.3 volume 1 of the Blue Book for detailed design of the sediment basin. • Impervious clay to be used where required in construction of the internal basin invert and embankments. • Inlet and outlet structures will be appropriately designed to cater for the nominated rainfall event. • Markers will be present to indicate sediment storage volume and to ensure adequate capacity levels are available. 	Supervisor / Environmental Site Representative	Site Establishment / Duration
Sediment basins will be constructed in a way that predominantly only site run-off is collected, and clean water is diverted around them. Earthworks will be conducted in a way so as to avoid ponding of water.	Supervisor / Environmental Site Representative	Site Establishment / Duration

Environmental Management Controls	Person Responsible	Timing / Frequency
The sediment basin/s to be constructed prior to any earthworks or topsoil stripping in the catchment being undertaken. Necessary clearing to access the basin location and associated earthworks will occur with appropriate erosion and sediment controls installed.	Supervisor / Environmental Site Representative	Site Establishment / Duration
Where applicable, the formation of operational sediment basins will be partially or fully constructed in early stages of works and managed as a temporary sediment basin to capture construction runoff.	Supervisor / Environmental Site Representative	Site Establishment / Duration
Effective diversions such as drains, and berms will be implemented to ensure that the diversion of site runoff is maximised to basins during all stages of construction.	Supervisor / Environmental Site Representative	Site Establishment / Duration
Water Quality Testing, Treatment & Criteria for Discharge		
Captured water to be discharged from sediment basins must meet the following criteria: <ul style="list-style-type: none"> • pH between 6.5 – 8.5 • TSS < 50mg/L; and • Oil and grease < 10mg/L (and no visible trace). 	Supervisor / Environmental Site Representative	Duration
<u>Correlation between TSS and Turbidity</u> A correlation between TSS and turbidity may be developed for the basin/s to allow discharge based on turbidity levels. This correlation will be submitted to the RMS Regional Environmental Manager and the NSW EPA for approval prior to implementation. Once approved, a TSS sample will be taken from every tenth discharge and tested to confirm compliance with required criteria. These results will be used to check and revise the correlation. If these tests indicate an exceedance of TSS criteria, discharges on the basis of turbidity measurements will be suspended until the correlation can be re-established and approved.	Environmental Manager / Environmental Site Representative	Duration
Potential contamination of any basin or ponded waters will be considered prior to discharge. Where the main source is from storm water, TSS and oil and grease are considered to be the likely pollutants. Where groundwater is a significant contributing source, influence from ASS/PASS or other contaminants will be considered as potential pollutants and additional testing in the form of pH and metals will be undertaken.	Supervisor / Environmental Site Representative	Duration
Water Treatment		
The sediment basin inlets will be pre-loaded with gypsum to pre-treat run-off before it enters the basin during rainfall	Supervisor / Environmental Site Representative	Duration
Onsite reuse of ponded stormwater or infiltrated groundwater should always be the first dewatering option considered. Onsite reuse may include application for dust suppression, earthworks compaction and vegetation establishment.	Supervisor / Environmental Site Representative	Duration
If water is to be used for construction purposes (e.g., compaction, dust control) no treatment is required. However, the water should be removed to re-secure design capacity of sediment basins within 5 days.	Supervisor / Environmental Site Representative	Duration
Tannins from timber and mulch stockpiles may also pose a risk to water quality however a pollutant limit is not specified for tannins. Dewatering of sediment basins that contain tannins must be demonstrated to occur in a manner that does not result in pollution of waters (e.g., reuse on site or irrigation to land). Mulch handling and stockpiles are to be managed in accordance with the TfNSW Environment Direction No.25 - Management of Tannins from Vegetation Mulch (2012).	Supervisor / Environmental Site Representative	Duration

Environmental Management Controls	Person Responsible	Timing / Frequency
If water is to be used for construction purposes (e.g., compaction, dust control) no treatment is required. However, the water should be removed to re-secure design capacity of sediment basins within 5 days.	Supervisor / Environmental Site Representative	Duration
All sediment basins to be inspected for capacity and water quality daily on workdays and within 24 hours (out of site hours) following cessation of a rain period.	Supervisor / Environmental Site Representative	Duration
<p>Before any de-watering of site areas, excavations, etc, the parameters of pH, T.S.S. and oil and grease are to be tested and meet. the following criteria:</p> <ul style="list-style-type: none"> • pH between 6.5 – 8.5 • TSS < 50mg/L; and • Oil and grease < 10mg/L (and no visible trace). <p>Treatment should commence as soon as practical following cessation of a rain to allow enough time for settlement of flocculants.</p>	Supervisor / Environmental Site Representative	Duration
<p>Records must be maintained for NSW EPA criteria, the laboratory Chain of Custody, the Water Discharge Permit and Water Discharge Register. The required records include:</p> <ul style="list-style-type: none"> • The date(s) on which the sample was taken, • The time(s) at which the sample was collected, • The point at which the sample was taken; and • The name of the person who collected the sample. 	Supervisor / Environmental Site Representative	Duration
<p>pH</p> <p>Treatment should be undertaken as follows:</p> <ul style="list-style-type: none"> • Test basin water with a suitable pH meter. No action is required if the pH reading is between 6.5 and 8.5 • Lime to be added if pH below 6.5 or Hydrochloric Acid (32% Muriatic) or Sulfuric Acid to be added if pH above 8.5 • Determine volume of water to be treated in the sediment basin. • Determine the percentage of lime or acid required by taking a 10-litre sample of basin water and adding a known amount of lime or acid (initially 0.004%). If the pH is still not acceptable, vary the amount of lime or acid until within the limits. • Once the required percentage has been determined, calculate the actual amount of lime or acid to be added by multiplying the volume of water in the basin by the determined percentage. • Add the required amount of lime or acid to the basin and mix the water in the sediment basin well • Treat for pH prior to T.S.S. 	Supervisor / Environmental Site Representative	Duration
<p>Total Suspended Solids</p> <ul style="list-style-type: none"> • Test the sediment basin water initially for NTU using a turbidity tube, nephelometer (Turbidity tester) or by comparing with water samples contained in jars with representative readings up to 100mg/l. • When the comparative NTU readings indicate T.S.S. levels are <50mg/l obtain a grab sample in accordance with approved sampling methods. The water sample to be promptly analysed by a laboratory that is NATA certified in T.S.S. testing. • No further treatment action is required if T.S.S. results are <50mg/l. 	Supervisor / Environmental Site Representative	Duration

Environmental Management Controls	Person Responsible	Timing / Frequency
<ul style="list-style-type: none"> If basins require flocculation (e.g., T.S.S. >50mg/l), gypsum is to be utilised at the manufacturers recommended dosage initially, then at an acceptable rate should more flocculant be required. Basins should be monitored daily after flocculation until desired TSS is achieved and to assist in determination of optimal dosage levels. <p>Methods of application to include:</p> <ul style="list-style-type: none"> broadcast by shovels on small sumps and excavations is acceptable. The general recommended dosage is 30kg/100 cubic meters. This method requires spreading gypsum evenly and thinly (i.e., “dusting”) over as much of the water surface as possible. For sediment basins or areas with a large water surface area. The gypsum should be pre-mixed thoroughly in a drum with clean water and sprayed over the maximum surface area of water as possible. When spraying flocculants, the mixture should hit the water at between 10 to 20 degrees to increase surface areas exposure to the water column. When using liquid gypsum, the general recommended dosage is 40L/megalitre When using liquid gypsum, the solution must be mixed before use to ensure gypsum is evenly suspended throughout mixture. This is best achieved using an aeration device at 3 bars of pressure for approximately 15 minutes. <p>The process outlined may need to be repeated if acceptable water quality is not achieved initially.</p>	Supervisor / Environmental Site Representative	Duration
<p><u>Oil and Grease</u></p> <ul style="list-style-type: none"> Examine surface of water for evidence (e.g., sheen, discoloration). No action if no visual contamination. Oil absorbent material to be spread if there is contamination (e.g., cell-u-sorb). Leave basins to compensate for 24 to 48 hours. 	Supervisor / Environmental Site Representative	Duration
<p>After retesting, and once the above field tests indicate, the water quality is acceptable, pumping or siphoning can commence with the water extraction inlet protected to prevent extraction of sediment.</p>	Supervisor / Environmental Site Representative	Duration
<p>Records to be kept of the rainfall events, inspections undertaken, field tests undertaken, dosage rates and when basin water is released etc.</p>	Supervisor / Environmental Site Representative	Duration
<p>The whole process of water quality management in sediment basins must be completed within 5 days of cessation of a rain period.</p>	Supervisor / Environmental Site Representative	Duration
Discharging Water		
<p>Existing farm dams that may require dewatering are likely to have variable water quality. The impact of water quality parameters or pollutants in existing farms dams to the receiving environment must be considered when planning a discharge from these storages.</p>	Supervisor / Environmental Site Representative	Duration

Environmental Management Controls	Person Responsible	Timing / Frequency
Where possible ponded water and sediment basin water will be reused on site for compaction, dust suppression, and irrigation.	Supervisor / Environmental Site Representative	Duration
Water may be discharged from site where the tested water quality meets all NSW EPA criteria, and the Environment Manager/Site Representative gives approval. The discharge outlet will be constructed to prevent erosion and scour.	Supervisor / Environmental Site Representative	Duration
The Supervisor is to ensure that treated water has been re-tested for pH and turbidity (NTU) in-situ immediately prior to discharge.	Supervisor / Environmental Site Representative	Duration
Where sediment basins are to be <u>dewatered by pump</u> , suitable inlet protection devices (i.e., float & housing or extraction tube) will be provided to prevent the extraction of settled sediments within the basin. The flows from the pump outlet and basin are to be constantly monitored during discharge.	Supervisor / Environmental Site Representative	Duration
Only personnel who have undertaken the relevant training and been approved by the Environment Manager may operate pumps and discharge sediment basins. During dewatering <u>pumps</u> must be always monitored to ensure that settled sediment is not disturbed or extracted, and that water is discharged in a diffused manner to prevent erosion.	Supervisor / Environmental Site Representative	Duration
A Sediment Basin Management Register will be maintained for each basin that details discharge volumes, dates, water treatment. The Sediment Basin Management Register will be updated when treated water is discharged from the basin.	Supervisor / Environmental Site Representative	Duration
Maintenance		
<p>Maintenance of the sediment basins will be ongoing for the duration of the Project and will comprise the following:</p> <ul style="list-style-type: none"> The sediment storage capacity limit will be defined through the installation of a marker inside the basin. Sediment will be removed from the basin in accordance with the maintenance schedule, or when the accumulated sediment exceeds 40% of the sediment storage zone. Sediment removed from basins may be reused on site by incorporating into spoil. All sediment that will not be reused on site will be disposed of in locations that it will not be conveyed back into the construction areas or watercourses. Maintenance inspections will be undertaken, and the results incorporated into the Weekly Environmental Inspection Checklist. 	Supervisor / Environmental Site Representative	Duration
The stormwater capacity of sediment basins will be reinstated within 5 days of the cessation of a rainfall event that causes runoff to occur	Supervisor / Environmental Site Representative	Duration
Storage and Handling of Flocculants		
Gypsum and agricultural lime will be stored on site as either bagged or bulk product. Storage of bulk gypsum and agricultural lime will be covered, within erosion and sediment controls in a position where run on water will not erode the stockpiles.	Supervisor / Environmental Site Representative	Duration
All treatment chemicals particularly acids and basics will be stored in appropriately bunded and covered locations that are locked to prevent unauthorised access.	Supervisor / Environmental Site Representative	Duration

Environmental Management Controls	Person Responsible	Timing / Frequency
All chemicals on site will be stored with MSDSs for ease of reference in the event of a spill or irritation/injury to handlers.	Supervisor / Environmental Site Representative	Duration
Requirements of the Material Safety Data Sheets (MSDSs) will be met to ensure compatible storage with other chemicals to ensure safety.	Supervisor / Environmental Site Representative	Duration
Monitoring and Record Keeping		
All sediment basins will be inspected on a weekly basis as a minimum, with any defects or maintenance requirements reported immediately. Sediment basins will be inspected immediately after rainfall events to assess: <ul style="list-style-type: none"> Water Storage capacity and water quality treatment requirements prior to discharge Following treatment and discharge from the sediment basin the sediment storage capacity and requirement for clean out will be assessed. 	Supervisor / Environmental Site Representative	Duration
The results of all inspections, including inspection reports will be retained in the site environmental inspection register	Supervisor / Environmental Site Representative	Duration
All discharges will be recorded on a discharge permit which will include: <ul style="list-style-type: none"> Volume to be discharged Treatment details (e.g., Coagulant/ flocculant used, dosage, duration and treatment date) Water quality monitoring results (including date and time of testing) Discharge water quality results Date and time of discharge 	Supervisor / Environmental Site Representative	Duration
Pumped discharge of any water off site will be monitored regularly to ensure that tested water quality meets all applicable criteria.	Supervisor / Environmental Site Representative	Duration
Decommissioning Construction Sediment Basins		
Construction sediment basins will remain in place until all upstream areas have been stabilised to achieve a 'C' Factor of 0.05 which equates to 70% groundcover as per Blue Book 7.1	Supervisor / Environmental Site Representative	Duration
All operational sediment basins will be desilted and reformed as per design requirements prior to completion of major works within the catchment.	Supervisor / Environmental Site Representative	Duration
Construction Sediment basins will be removed by restoring the ground disturbed by the construction of the basin similar to pre-existing conditions. This will be achieved by: <ul style="list-style-type: none"> Removing all redundant basin equipment such as basin markers, siphons, spillway linings, etc. Spreading and compacting the embankment material in the basin area Disturbed ground will be compacted to at least the relative density of the material in the ground adjacent to it. 	Supervisor / Environmental Site Representative	Duration

3. Procedure Review

The procedure will be regularly reviewed as part of the CEMP audit requirements. This document will be updated when needed in response to audit findings or changes to site conditions. The Environmental Manager in consultation with RMS will modify the procedure where improvements are identified.

Appendix D:
Site Dewatering Discharge Record

Site Dewatering Discharge Record

Date Inspected		Basin/discharge point ID:		
Date of last rainfall event:		Amount of rainfall received:		
Estimated basin/sump level in %?		Approximate volume of water in basin/sump prior to treatment:		
Initial turbidity reading of the basin in NTU's		Initial pH of the basin? (range of 6.5 -8.5 required)		
The initial amount of acid/lime used if pH correction is required.		Date & time of acid/lime dosing	/ /	
			am/pm	
Subsequent amount of acid/lime used if pH correction is required.		Date & time of acid/lime dosing	/ /	
			am/pm	
Type of flocculant or coagulant product used (and typical dosing volume)	Yes	No	Flocculant or coagulant product used	Date & time of flocculant or coagulant dosing
Calcium Sulphate (Gypsum - powder) 300ppm (30kg/100m3)				/ /
				am/pm
Anionic Polyacrylamide (gel blocks) 200ppm (20kg/100m3)				/ /
				am/pm
Calcium Chloride (solid - flakes) 200ppm (20kg/100m3)				/ /
				am/pm
Aluminium Chlorohydrate (liquid) 40ppm (4L/100m3)				/ /
				am/pm
PAC23 (poly aluminium chloride 23% - solution) 50ppm (12.5L/100m3)				/ /
				am/pm
Aluminium Sulphate (crystals) 200ppm (20kg/100m3)				/ /
				am/pm
Turbidity reading of the basin in NTU's			Laboratory TSS Result: (if applicable)	
Time and Date of dewatering (i.e., siphon valve opened for discharge or commencement of pump operation)				/ /
				am/pm
Supervisor responsible for discharge:		Name:		
Date:		Signed:		
Comments? (E.g., next rainfall predicted – slight, moderate, severe?) Was rainfall received during treatment period affecting basin (start a new sheet)				

Appendix E

Wet weather contingency procedure

1.1 Purpose

The purpose of the Wet Weather Contingency Procedure (the Procedure) is to detail the actions to be taken by construction personnel in response to an imminent severe rainfall event as forecast by the Australian Government - Bureau of Meteorology (BOM). The procedure provides guidance for monitoring BOM rainfall & storm event forecasts and other resources, to assist with Project preparations to minimise adverse site impacts where practical.

Adherence to the methodology outlined in procedure will ensure that works for wet weather contingency planning & implementation will be carried out in accordance with contract specifications and to maximise adherence to environmental obligations.

The purpose of the Wet Weather Contingency Procedure is to:

- Identify rainfall events which may cause significant precipitation over the site areas which would result in flash flooding and/or exacerbate erosion and sediment impacts,
- Include monitoring procedures of the Bureau of Meteorology (BOM) weather forecasts to predict severe rainfall events,
- Ensure emergency procedures are developed for the management of work areas, facilities and materials in a severe rainfall event that has the potential to impact areas of the Site,
- Ensure hazardous chemical & fuel/oil storage and stockpile areas are positioned in locations to limit the potential for adverse impacts from major runoff flows and/or flash flooding,
- Outline control measures for the protection of water quality in the event of a flood over the site,
- Ensure progressive stabilising methods for areas that may be potentially affected by flash flooding and/or significant scouring & erosion are implemented.

1.2. Scope

The Procedure applies to the following:

- Weather forecast monitoring and works planning,
- Implementation, monitoring and maintenance of erosion and sediment controls,
- Stockpile and hazardous materials storage,
- Sediment basin management, dewatering and maintenance.

1.3. Objectives

The objectives of this Procedure are to:

- Ensure all Project personnel are aware of the requirements of this procedure,
- Detail personnel responsible for undertaking actions relating to works planning, erosion and sediment control management, sediment basin management & construction dewatering on the site,
- Comply with environmental requirements of the Project, including all legal requirements and contractual obligations.

2. Wet Weather Contingency & Management

Environmental Management Controls	Person Responsible	Timing / Frequency
Planning		
A copy of this Wet Weather Contingency Procedure will be kept on site and be made available to all relevant project personnel	Supervisor / Environmental Site Representative	Site Establishment / Duration
All relevant project personnel will be made aware of this document during the site induction and again in Toolbox Talks and targeted training sessions.	Supervisor / Environmental Site Representative	Site Establishment / Duration
Training and Awareness		
Training & instruction of site personnel will be the responsibility of the Environment Manager/ Environmental Site Representative.	Environmental Site Representative	Site Establishment / Duration
Training sessions will be conducted with Supervisors, Foreman, Environmental Work Crew, and relevant personnel. The training will address <ul style="list-style-type: none"> • Weather forecast monitoring procedures and interpretation of forecasting by BOM and other sources • Site erosion and sediment control status and high-risk areas • Roles and responsibilities for wet weather preparation • Temporary measure selection for augmentation or additional ERSED measures • Pre & post-rainfall inspections and recording • Dewatering requirements, methods, and recording • Identification of stabilisation and rectification works required. 	Supervisor / Environmental Site Representative	Site Establishment / Duration
Identification of significant rainfall events		
The daily BOM forecast for the local area is issued each morning and late afternoon. The forecasts will be monitored daily, at the start of the shift and prior to shut down. The BOM three-day forecast outlook will be reviewed daily.	Supervisor / Environmental Site Representative	Duration
BOM forecasts indicating a high likelihood of storm fronts or rainfall events of >10mm with an occurrence probability of more than 50% will be regarded as a potential rainfall event.	Supervisor / Environmental Site Representative	Duration
In periods of forecast storm weather or likely rainfall events, the tracking and intensity of approaching weather fronts is to be monitored regularly (where possible) to anticipate the time of the onset of wet weather.	Supervisor / Environmental Site Representative	Duration
Wet Weather Management Procedures		
Where a potential rainfall event is deemed likely in the BOM three-day outlook, Project personnel are to review the scope and progress of existing and imminent site works to determine high risk areas and prioritise works to stabilise the nominated areas. High risk works include culvert works, scour protection installation, permanent drainage installation, trenching on grade, and sediment basin construction or maintenance.	Project Manager / Senior Engineer / Supervisors / Environmental Site Representative	Duration

Environmental Management Controls	Person Responsible	Timing / Frequency
Wet Weather Management Procedures		
<p>The high-risk work areas that are identified will be managed by:</p> <ul style="list-style-type: none"> • Completion and temporary/permanent stabilisation of the high-risk work areas where time & resource constraints allow, prior to the onset of the potential rainfall event. • Re-allocating resources from low-risk activities to assist with completion of high risk works prior to the onset of a rainfall event. • Implementation of erosion controls in high-risk areas to minimise sediment control requirements. Erosion controls will be employed such as: <ul style="list-style-type: none"> ○ temporary geotextile linings or soil binders will be installed around culverts, scour protection works and drain junctions, ○ sandbag check dams, rock baffles, trench stops, etc will be utilised in open trenching on grade, temporary diversion drains, or concentrated flow paths over unstabilised areas. 	Project Manager / Senior Engineer / Supervisors / Environmental Site Representative	Duration
<p>The site sediment controls, and sediment basins are to be inspected and any necessary rectification works undertaken such as;</p> <ul style="list-style-type: none"> • Sediment basins are to be managed in accordance with Sediment Basin Management Procedure to regain the maximum runoff capacity parameters, where possible, • Sediment traps and filters to be desilted where more than 40% storage capacity is exceeded, • Spillways and discharge points from sediment traps to be inspected and reinstated as required. • Sediment fences, mulch bunds, earth berms to be inspected and repairs or reinstatement implemented as required. 	Supervisor / Environmental Site Representative	Duration
<p>The chemical, fuel and other hazardous material storage areas to be inspected to ensure their location is protected from the ingress of rainfall or concentrated overland flows. Bund controls to be inspected and accumulated liquids or other residues removed to a controlled waste location on site or for offsite disposal at licensed premises.</p>	Supervisor / Environmental Site Representative	Duration
<p>Following the onset of a significant storm event or rainfall event, the site controls to be inspected as soon as site conditions and safety requirements allow. The inspection to focus on high-risk areas to review the function and status of the installed erosion and sediment controls.</p>	Supervisor / Environmental Site Representative	Duration
<p>In the event that a potential flood event is anticipated, the Flood Management Procedure would be enacted for removing plant, equipment and materials from the site prior to a minimum 1 in 20-year flood event.</p>	Project Manager / Senior Engineer / Supervisors / Environmental Site Representative	Duration
Post-Rainfall/Storm Procedure		
<p>The Post Rainfall Inspection will be conducted in accordance with Section 7.7 of this ESCP. The identified high-risk areas will be prioritised for any rectification or maintenance works, followed by areas with lower risk.</p>	Supervisor / Environmental Site Representative	Duration
<p>Records detailing the necessary works to reinstate the controls will be conducted in accordance with Section 7.7 of this ESCP.</p>	Supervisor / Environmental Site Representative	Duration

Environmental Management Controls	Person Responsible	Timing / Frequency
Sediment basins are to be managed in accordance with Sediment Basin Management Procedure. Flocculation of the sediment basins may occur soon after the cessation of a rainfall event to improve the water quality parameters in circumstances where further significant rainfall is anticipated.	Supervisor / Environmental Site Representative	Duration
High risk work areas that are inundated will be prioritised for dewatering by: <ul style="list-style-type: none"> • Dewatering to a sediment basin where sufficient capacity is available, • Flocculated in-situ and discharged at a licensed discharge point when NSW EPA water quality parameters are attained, • Dewatered by water cart and utilised for construction purposes. 	Supervisor / Environmental Site Representative	Duration
Repair and reinstatement of erosion and sediment controls to be implemented as site conditions allow, proceeding from high-risk areas to lower risk areas on site.	Supervisor / Environmental Site Representative	Duration

3. Procedure Review

The procedure will be regularly reviewed as part of the CEMP audit requirements. This document will be updated when needed in response to audit findings or changes to site conditions. The Environmental Manager in consultation with TfNSW will modify the procedure where improvements are identified.

Appendix F

Progressive Erosion and Sediment Control Plan

NOTES - Administration & General

1. This progressive plan is to be read in conjunction with the, PMP, relevant specifications, and procedures.
2. Works programming to maximise the mitigation of erosion by the early implementation of permanent drainage measures, temporary and permanent soil surface stabilisation measures, and minimising the area and duration of soil disturbance.
3. Bureau of Meteorology weather forecasting to be monitored daily for the local 7-Day weather outlook. Site management measures to be planned for imminent storm/rainfall/flood/wind events include, but are not limited to;
 - avoiding additional soil disturbance immediately prior to an event,
 - provision of additional erosion and sediment controls in critical locations,
 - installing, repairing, and/or adjusting 'clean' (off site water) and 'dirty' (on site) water drainage measures,
 - desilting and re-instating sediment controls as required,
 - implementing stockpile protection measures,
 - stabilising and sealing disturbed soil surfaces,
 - minimising dry soil handling in windy conditions,
 - evacuating or protecting erodible materials in lower lying area.
4. The plan is to be revised as necessary (i.e. progression of works, altered site conditions or weather). The controls depicted are subject to staging and the controls may be progressively implemented or removed according to progression of works.
5. All erosion and sediment controls generally to be constructed in accordance with 'Blue Book' specifications and standard drawings being
 - MANAGING URBAN STORM WATER: SOILS AND CONSTRUCTION - 4th EDITION, LANDCOM, MARCH 2004;
 - MANAGING URBAN STORM WATER: SOILS AND CONSTRUCTION – VOLUME 2D MAIN ROAD CONSTRUCTION, DEC, 2008;
 - RMS QA SPECIFICATION G36 - ENVIRONMENTAL MANAGEMENT (SOIL AND WATER MANAGEMENT PLAN)
6. Substitute materials may be utilised in the construction of erosion or sediment controls where functionality is not affected, i.e. compacted mulch bunds in place of sediment fences, stabilised earth Berms in place of excavated drains near underground services or timber pegs in place of star pickets where electrical or gas.
7. Personnel constructing controls to have demonstrated competence and experience. Specific awareness training and workshops to be undertaken by personnel with direct involvement with erosion and sediment control. Toolbox talks to regularly focus on erosion and sediment control for specific works, associated risks, potential impacts and mitigation measures.
8. All existing vegetated or undisturbed areas outside of the works area to be regarded as "No Go" zones and to be delineated with fencing, tape or other markers, as required. All site personnel to be instructed to avoid "No Go" zones or damaging installed controls.

Erosion Control

9. Prior to commencement of significant works, install surface drains, sediment traps, sumps & filters, and other surface runoff control measures to control runoff onto, across, and from the works zones to prevent the loss of sediment from the site.
10. Construction zones in constrained areas to be managed in smaller, defined sub-catchments to reduce slope lengths and minimise sediment loads to boundary controls.
11. Short term on-site stockpiles to be located away from drains and flow lines and be controlled with sediment fence or storm covers.
12. Any significant (long & steep) cut/fill batters should be progressively overlaid with Rolled Erosion Control Products (RECP's such as jute mesh, coir fibre mesh, etc), mulching, Organic Fibre Mulches (OFM's) or geobinders to reduce erosion and rilling, prior to permanent stabilisation with cover crops, mulching or other long-term surface protection
13. Vehicles transporting bulk materials on public roads are to correctly cover loads to prevent loss of load and/or dust generation.
14. Temporary controls in addition to those shown may be required at strategic locations as required by the progression of works or weather conditions

Water Management (Cont'd)

15. Maximise the interception and diversion of 'clean' (off site water) away from works areas. The 'clean' flows to be conveyed in stabilised drainage lines to suitable discharge points. The flows to be discharged to off-site areas at non-erosive velocities with adequate diffusers, level spreaders, etc. Ensure drainage paths and controls are adjusted as required to maximise the separation of 'clean' (off site) and 'dirty' (on site) water flows through/off site.
- 16.

17. Flows paths with high velocity flows over unstabilised areas to be controlled with
 - applied soil surface stabilisers i.e. geotextile lining, applied soil binders, coarse rock lining, etc
 - suitably constructed check dams placed at intervals to maximise flow suppression and settling of coarse sediment.
18. Where possible, provide sand bag or other bunding controls at on-site collection points & pit inlets to prevent flows bypassing controls to downslope areas.
19. Protect all existing and constructed inlets to pits & culverts from sediment ingress.
20. Where practical, maintain and/or improve existing stabilised drains to assist in the diversion of 'clean' (off site) flows.
21. Flooded excavations, ponded water, etc. to be extracted and tested prior to off-site disposal, utilised for site purposes, or treated to achieve acceptable water quality prior to discharge.

Sediment Control

22. The installation of preliminary sediment controls such as perimeter sediment fencing, windrowed vegetation/mulch, excavated sediment traps, check dams, straw bale filters, etc, will be implemented prior to soil disturbance within the catchment.
23. Accumulated water in sediment traps/sumps cannot be pumped, discharged or released from site without completing a dewatering checklist and gaining approval from the Site Manager.
24. Appropriate sediment tracking controls such as an aggregate/geotextile apron, shaker grid, etc. will be installed at exit points from the site. Personnel to monitor roadways & tracked sediments to be removed as required.
25. Personnel to ensure visual dust monitoring is maintained during works, and dust suppression is undertaken regularly. Dust control to be regularly conducted with water carts and soil stockpiles to suitably covered. Additional dust suppression measures to be utilised to minimise dust pollution during periods of high winds.
26. Temporary 'dirty' water drainage will be adjusted progressively to maximise flows to sediment control devices.

Contamination

29. Excavation of sub-soils to be inspected and monitored as works proceeds, to identify potential contamination. Any potentially contaminated soils to be stripped or excavated separately and transported directly to the designated stockpile, treatment area or licensed waste facility.
30. Potentially contaminated soils are to be stored within an appropriately bunded area and covered with heavy grade plastic or other impermeable covers for the duration of rainfall.
31. Ground disturbance and machinery/vehicle movements in potentially contaminated areas will be minimised to essential works.

Monitoring & Reporting and Inspection & Maintenance

32. Inspections of erosion and sediment controls will occur following rainfall events >10mm (daily on work days or as soon as practical during site shutdown periods), with any necessary repairs implemented as soon as possible.
 33. Relevant checklists and records to be maintained noting details such as rainfall received, repairs to controls and amounts of sediments cleaned from controls.
 34. Sediment traps, sumps and filters are to be desilted when 40% of storage capacity is reached.
 35. All site personnel to report any spill, leaks, or other failure to relevant response staff as soon as possible.
- Stabilisation
36. Erosion and sediment controls are to be maintained until the relevant catchments are stabilised, re-vegetated, or sealed adequately to achieve soil surface protection factors as per the 'Blue Book' and SWMP requirements.
 37. Completed earthworks areas will be backfilled and compacted in a staged manner as soon as possible. Adjacent disturbed areas will be suitably trimmed and stabilised as required.
 38. Stabilisation of areas is to occur progressively in conjunction with the completion of earthworks.
 39. Areas subject to heavy compaction and disturbance from vehicle movements and machinery to be scarified to a depth >100mm prior to topsoiling and seeding.

Version	Drawn by	Date	Signed	Reviewed by	Date
01	A. Littlewood	22/04/2024			
02	A. Littlewood	17/05/2024			
03	A. Littlewood	08/11/2024			

Stage 1 - Western Carpark – Demolition & early earthworks

The existing landscaped garden to be retained as existing where practical. The landscaped area may be utilised for diffused irrigation of minor amounts of surface water (i.e. hand watered or soaker hoses). Any groundwater from depth should be tested to ensure acceptable water quality parameters prior to any on-site re-use (i.e., soil conditioning, dust suppression, etc). Sediment fence to be installed along the back of the existing kerb if the landscaped area is to be used for irrigation.

Geotextile of A34 grade or above to be wrapped around the existing pit grates during demolition. The controls to be monitored and desilted and or replaced after rain events.

Geotextile of A34 grade or above to be installed by pinning the fabric to the existing boundary fence mesh at 1000mm centres. The toe of the fabric to be extended as an apron over the existing concrete kerb and then be continuously weighted at the toe with clean aggregate, coarse sand, sandbags or similar.

In the event the existing asphalt pavement is removed, the site access aprons to be stabilised with, but not limited to, suitable materials such as asphalt millings, road base material, clean quarry aggregate, recycled concrete, etc. Coir logs to be positioned across the access points during rainfall or extended site shutdown.

The red shaded area indicates the Stage 2 work area which will follow the commencement of Stage 1 works.

Following demolition of pavements and the commencement of early earthworks, an excavated sump with a volume of 105m³ should be formed in a low-lying area of the catchment. The position of the sump shown on the plan is indicative only and the location may change with the progression of works. The sump is likely to be positioned in the proposed stairwell or lift shaft excavations. Collected runoff in the sump to be treated, tested, and discharged within two-days of the

Catchment Name	West Carpark
Total Catchment Size (ha)	1.05
Existing Catchment Grade (%)	2%
RUSLE grade adopted	2%
Basin Tag	N/A
RUSLE soil loss - M ³ /Ha/Yr	28
Catchment soil loss x catchment area - M ³ /Ha/Yr	29.4
Sediment Basin required? (<150 M ³ /Ha/Yr) Blue Book S 6.3.2.	No
Calculated 5-Day basin volume (M ³) - Type D	212 M ³
Calculated 2-Day basin volume (M ³) - Type D	103 M ³



Legend											
Off Site Water – Sheet Flows		Piped Drainage		Stabilised Topsoil Berm (geo/jute/seed)		Sediment basin / large sump		Sediment Fence Geotextile Apron		Vegetated filter	
Off Site Water – Concentrated Flow/Drain		Off-site & onsite water cross-over		Stabilised or lined drain		Filter bag / rock & shade cloth sediment filter		Geotextile wrapped grate pit inlet		Controlled site access Wheel Wash	
On Site Water - Concentrated Flow/Drain		'Off site' water exclusion bank		Rock lined drain or lined spillway		Compacted Mulch / Rock & Geotextile / topsoil sediment trap		Coir Log / Straw bale filter		Stabilised Haul Road/Access Track/ Piling pad/Piped crossing	
On Site Water – Sheet Flows		Level Spreader / Diffuser		Coarse rock / sandbag check dam		Excavated sediment trap with spill weir		Filter bag or sediment fence inlet filter		Traffic Barriers / Timber Hoarding	

Stage 2 - Eastern Carpark – Demolition & early earthworks

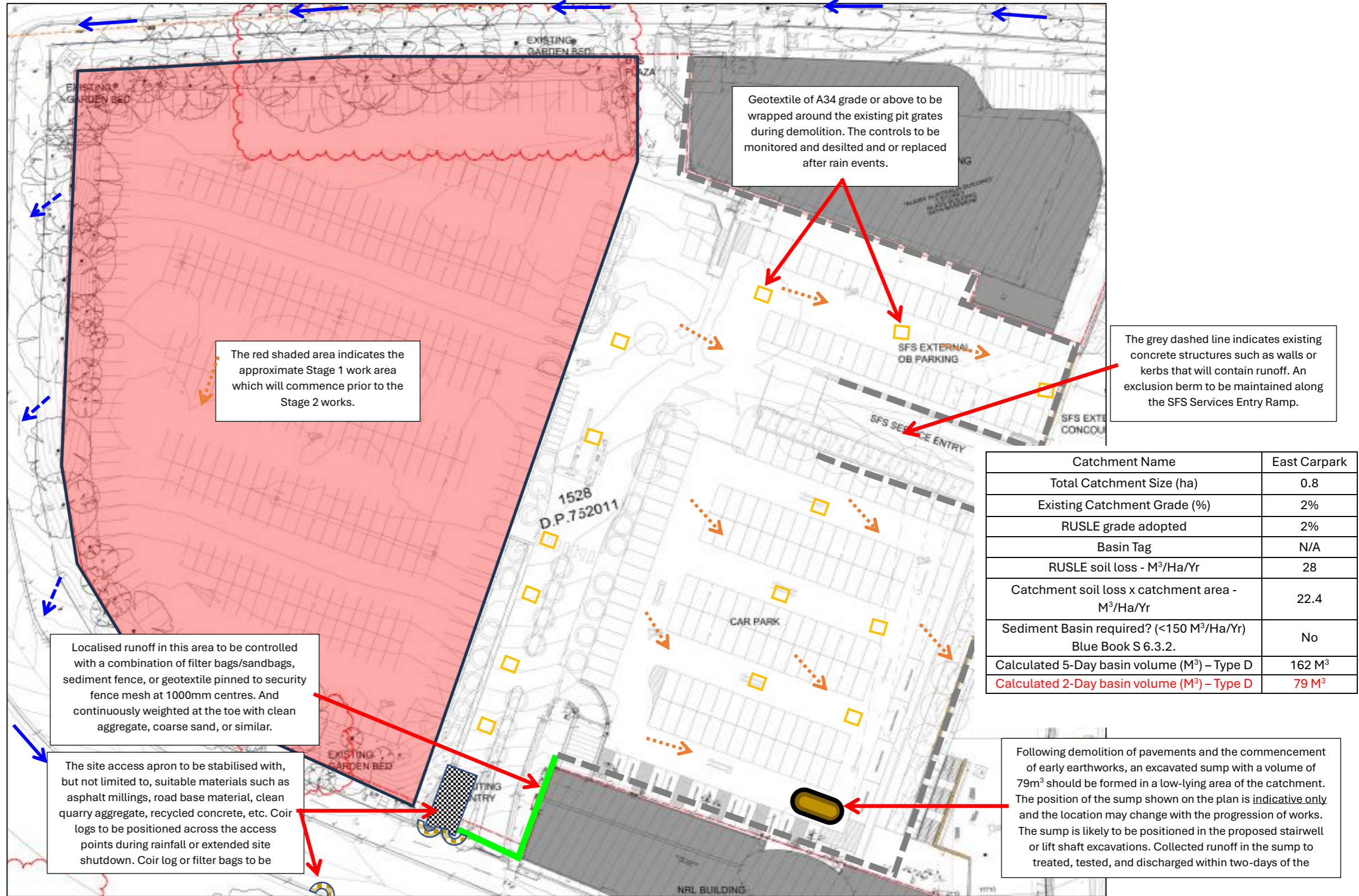

Legend											
Off Site Water – Sheet Flows		Piped Drainage		Stabilised Topsoil Berm (geo/jute/seed)		Sediment basin / large sump		Sediment Fence Geotextile Apron		Vegetated filter	
Off Site Water – Concentrated Flow/Drain		Off-site & onsite water cross-over		Stabilised or lined drain		Filter bag / rock & shade cloth sediment filter		Geotextile wrapped grate pit inlet		Controlled site access Wheel Wash	
On Site Water - Concentrated Flow/Drain		'Off site' water exclusion bank		Rock lined drain or lined spillway		Compacted Mulch / Rock & Geotextile / topsoil sediment trap		Coir Log / Straw bale filter		Stabilised Haul Road/Access Track/ Piling pad/Piped crossing	
On Site Water – Sheet Flows		Level Spreader / Diffuser		Coarse rock / sandbag check dam		Excavated sediment trap with spill weir		Filter bag or sediment fence inlet filter		Traffic Barriers / Timber Hoarding	

Stage 3 – Bulk earthworks & Foundation Structures

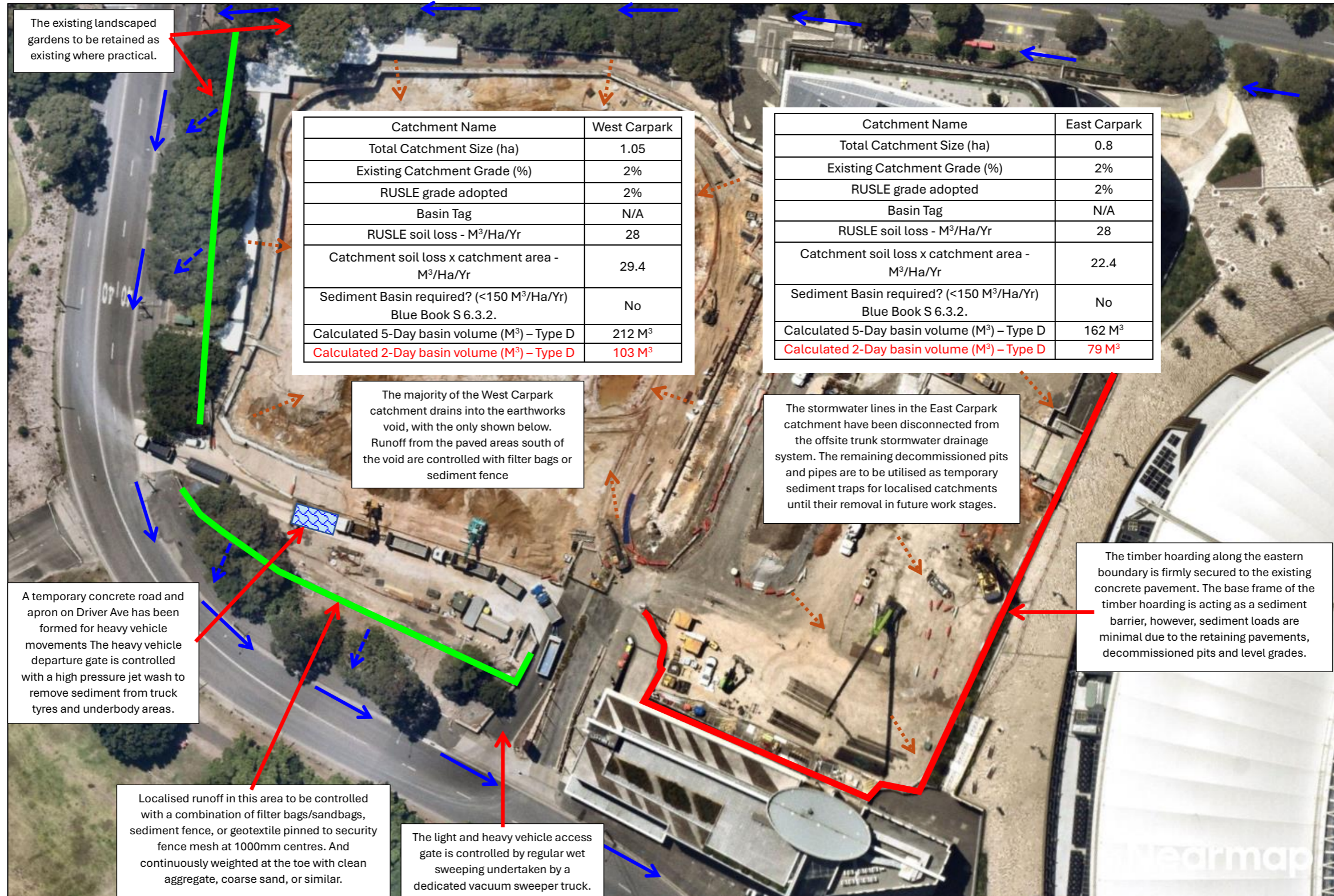

Legend											
Off Site Water – Sheet Flows		Piped Drainage		Stabilised Topsoil Berm (geo/jute/seed)		Sediment basin / large sump		Sediment Fence Geotextile Apron		Vegetated filter	
Off Site Water – Concentrated Flow/Drain		Off-site & onsite water cross-over		Stabilised or lined drain		Filter bag / rock & shade cloth sediment filter		Geotextile wrapped grate pit inlet		Controlled site access Wheel Wash	
On Site Water - Concentrated Flow/Drain		'Off site' water exclusion bank		Rock lined drain or lined spillway		Compacted Mulch / Rock & Geotextile / topsoil sediment trap		Coir Log / Straw bale filter		Stabilised Haul Road/Access Track/ Piling pad/Piped crossing	
On Site Water – Sheet Flows		Level Spreader / Diffuser		Coarse rock / sandbag check dam		Excavated sediment trap with spill weir		Filter bag or sediment fence inlet filter		Traffic Barriers / Timber Hoarding	

Standard drawings

Construction Notes

- Place stockpiles more than 2 (preferably 5) metres from existing vegetation, concentrated water flow, roads and hazard areas.
- Construct on the contour as low, flat, elongated mounds.
- Where there is sufficient area, topsoil stockpiles shall be less than 2 metres in height.
- Where they are to be in place for more than 10 days, stabilise following the approved ESCP or SWMP to reduce the C-factor to less than 0.10.
- Construct earth banks (Standard Drawing 5-5) on the upslope side to divert water around stockpiles and sediment fences (Standard Drawing 6-8) 1 to 2 metres downslope.

STOCKPILES SD 4-1

Construction Notes

- Remove any rocks, clods, sticks or grass from the ground surface before laying the matting.
- Spread topsoil to at least 75 mm depth.
- Where appropriate, complete fertilising and seeding on a properly prepared seedbed (Standard Drawing 7-1) before laying the matting.
- Ensure the fabric can be continuously in contact with the soil by grading the surface carefully first.
- Lay the matting in "shingle-fashion" with the ends of each upstream roll overlapping the next roll downslope.
- Ensure sufficient stakes are used to maintain a good contact between the soil and the matting.

RECP : SHEET FLOW SD 5-2

Construction Notes

- Remove any rocks, clods, sticks or grass from the surface before laying matting.
- Ensure that topsoil is at least 75 mm deep.
- Complete fertilising and seeding before laying the matting.
- Ensure fabric will be continuously in contact with the soil by grading the surface carefully first.
- Lay the fabric in "shingle-fashion", with the end of each upstream roll overlapping those downstream. Ensure each roll is anchored properly at its upslope end (Standard Drawing 5-7b).
- Ensure that the full width of flow in the channel is covered by the matting up to the design storm event, usually in the 10-year ARI time of concentration storm event.
- Divert water from the structure until vegetation is stabilised properly.

RECP : CONCENTRATED FLOW SD 5-7

Construction Notes

- Check dams can be built with various materials, including rocks, logs, sandbags and straw bales. The maintenance program should ensure their integrity is retained, especially where constructed with straw bales. In the case of bales, this might require their replacement each two to four months.
- Trench the check dam 200 mm into the ground across its whole width. Where rock is used, fill the trenches to at least 100 mm above the ground surface to reduce the risk of undercutting.
- Normally, their maximum height should not exceed 600 mm above the gully floor. The centre should act as a spillway, being at least 150 mm lower than the outer edges.
- Space the dams so the top of the upstream dam is level with the spillway of the next downstream dam.

ROCK CHECK DAM SD 5-4

Construction Notes

- Build with gradients between 1 percent and 5 percent.
- Avoid removing trees and shrubs if possible - work around them.
- Ensure the structures are free of projections or other irregularities that could impede water flow.
- Build the drains with circular, parabolic or trapezoidal cross sections, not V shaped.
- Ensure the banks are properly compacted to prevent failure.
- Complete permanent or temporary stabilisation within 10 days of construction.

EARTH BANK (LOW FLOW) SD 5-5

Construction Notes

- Construct at the gradient specified on the ESCP or SWMP, normally between 1 and 5 percent.
- Avoid removing trees and shrubs if possible - work around them.
- Ensure the structures are free of projections or other irregularities that could impede water flow.
- Build the drains with circular, parabolic or trapezoidal cross sections, not V-shaped, at the dimensions shown on the SWMP.
- Ensure the banks are properly compacted to prevent failure.
- Complete permanent or temporary stabilisation within 10 days of construction following Table 5.2 in Landcom (2004).
- Where discharging to erodible lands, ensure they outlet through a properly constructed level spreader.
- Construct the level spreader at the gradient specified on the ESCP or SWMP, normally less than 1 percent or level.
- Where possible, ensure they discharge waters onto either stabilised or undisturbed disposal sites within the same subcatchment area from which the water originated. Approval might be required to discharge into other subcatchments.

EARTH BANK (HIGH FLOWS) SD 5-6

Stabilised topsoil diversion bank

Construction Notes

- Construct with gradient of 1% to 5%.
- Avoid removing trees and shrubs if possible - work around them.
- Drains to be circular, parabolic or trapezoidal cross section not V-shaped.
- Earth bank to be adequately compacted in order to prevent failure.
- Permanent or temporary stabilisation of the earth bank to be completed within 10 days of construction.
- All outlets from disturbed lands are to be fed into a sediment basin or similar discharge runoff collection from undisturbed lands onto either a stabilised or an undisturbed disposal site within the same subcatchment area from which the water originated.
- Compact bank with a suitable implement in situations where they are required to function for more than five days.
- Earth bank to be free of projections or other irregularities that will impede normal flow.

EARTH BANK (ONSITE & OFFSITE COMBINED) SD 5-7

Construction Notes

- CONSTRUCT WITH GRADIENT OF 1% TO 5%.
- AVOID REMOVING TREES AND SHRUBS IF POSSIBLE - WORK AROUND THEM.
- DRAINS TO BE CIRCULAR, PARABOLIC OR TRAPEZOIDAL CROSS SECTION NOT V-SHAPED.
- EARTH BANK TO BE ADEQUATELY COMPACTED IN ORDER TO PREVENT FAILURE.
- PERMANENT OR TEMPORARY STABILISATION OF THE EARTH BANK TO BE COMPLETED WITHIN 10 DAYS OF CONSTRUCTION.
- ALL OUTLETS FROM DISTURBED LANDS ARE TO BE FED INTO A SEDIMENT BASIN OR SIMILAR DISCHARGE RUNOFF COLLECTION FROM UNDISTURBED LANDS ONTO EITHER A STABILISED OR AN UNDISTURBED DISPOSAL SITE WITHIN THE SAME SUBCATCHMENT AREA FROM WHICH THE WATER ORIGINATED.
- COMPACT BANK WITH A SUITABLE IMPLEMENT IN SITUATIONS WHERE THEY ARE REQUIRED TO FUNCTION FOR MORE THAN FIVE DAYS.
- EARTH BANK TO BE FREE OF PROJECTIONS OR OTHER IRREGULARITIES THAT WILL IMPEDE NORMAL FLOW.

GENERAL CONSTRUCTION NOTES

Standard drawings

PLAN VIEW

Discharge to unconfined section (Flared outlet)
Minimum collector condition

Dimensions to be supplied on SWMP

PLAN VIEW

Discharge pipe
Existing stabilised channel
Needle-punched geotextile
Toe wall
75 mm min. aggregate

CROSS SECTION AA

75 mm min. aggregate

Construction Notes

1. Compact the subgrade fill to the density of the surrounding undisturbed material.
2. Prepare a smooth, even foundation for the structure that will ensure that the needle-punched geotextile does not sustain serious damage when covered with rock.
3. Should any minor damage to the geotextile occur, repair it before spreading any aggregate. For repairs, patch one piece of fabric over the damage, making sure that all joints and patches overlap more than 300 mm.
4. Lay rock following the drawing, according to Table 5.2 of Lansdon (2004) and with a minimum diameter of 75 mm.
5. Ensure that any concrete or riprap used for the energy dissipater or the outlet protection conforms to the grading limits specified on the SWMP.

ENERGY DISSIPATER SD 5-8

Construction site

Min. width 3 metres

Min. length 15 metres

200 mm min.

300 mm min.

Property boundary

Runoff directed to sediment trap/fence

D9B 20 roadbase or 30 mm aggregate

Existing roadway

Geotextile fabric designed to prevent intermingling of roadbase and base materials and to maintain good properties of the sub-base layers.

Geofabric may be a woven or needle-punched product with a minimum CBR burst strength (AS3706.4-90) of 2500 N

Construction Notes

1. Strip the topsoil, level the site and compact the subgrade.
2. Cover the area with needle-punched geotextile.
3. Construct a 200-mm thick pad over the geotextile using road base or 30-mm aggregate.
4. Ensure the structure is at least 15 metres long or to building alignment and at least 3 metres wide.
5. Where a sediment fence joins onto the stabilised access, construct a hump in the stabilised access to divert water to the sediment fence

STABILISED SITE ACCESS SD 6-14

15 m star pickets at max. 2.5 m centres

500 mm to 600 mm

600 mm min.

Direction of flow

Self-supporting geotextile

On soil, 150 mm x 100 mm trench with compacted backfill and on rock set into surface concrete

SECTION DETAIL

15 m star pickets at max. 2.5 m centres

Direction of flow

Undisturbed area

20 m max. (unless stated otherwise on SWMP/ESCP)

Flow

Min. 1.5 m

Star pickets at maximum 2.5 m spacings

PLAN

Construction Notes

1. Construct sediment fences as close as possible to being parallel to the contours of the site, but with small returns as shown in the drawing to limit the catchment area of any one section. The catchment area should be small enough to limit water flow if concentrated at one point to 50 litres per second in the design storm event, usually the 10-year event.
2. Cut a 150-mm deep trench along the upslope line of the fence for the bottom of the fabric to be entrenched.
3. Drive 1.5 metre long star pickets into ground at 2.5 metre intervals (max) at the downslope edge of the trench. Ensure any star pickets are fixed with safety caps.
4. Fix self-supporting geotextile to the upslope side of the posts ensuring it goes to the base of the trench. Fix the geotextile with wire ties or as recommended by the manufacturer. Only use geotextile specifically produced for sediment fencing. The use of shade cloth for this purpose is not satisfactory.
5. Join sections of fabric at a support post with a 150-mm overlap.
6. Backfill the trench over the base of the fabric and compact it thoroughly over the geotextile.

SEDIMENT FENCE SD 6-8

F82 mesh support

geotextile

rock or gravel anchoring

sand bag or rock anchoring

trenchmesh supports at 2 metre centres

Construction Notes

1. Install this type of sediment fence when use of support posts is not desirable or not possible. Such conditions might apply, for example, where approval is granted from the appropriate authorities to place these fences in highly sensitive estuarine areas.
2. Use bent trench mesh to support the F82 welded mesh facing as shown on the drawing above. Attach the geotextile to the welded mesh facing using UV resistant cable ties.
3. Stabilise the whole structure with sandbag or rock anchoring over the trench mesh and the leading edge of the geotextile. The anchoring should be sufficiently large to ensure stability of the structure in the design storm event, usually the 10 year event.

ALTERNATIVE SEDIMENT FENCE SD 6-9

Spillway

Sediment storage zone

Length

Width

Length/width ratio 3:1 min.

Earth embankment

Plan View

Original ground level

Sediment settling zone

600 mm min.

750 mm min.

Crest of spillway

Water depth 1500 mm min.

Cross-section

Out-wash trench 800 mm min. depth backfilled with impermeable clay and compacted

Construction Notes

1. Remove all vegetation and topsoil from under the dam wall and from within the storage area.
2. Construct a cut-off trench 800 mm deep and 1,200 mm wide along the centre-line of the embankment extending to a point on the gully wall level with the crest.
3. Maintain the trench free of water and recompact the materials with equipment as specified in the SWMP to 95 per cent Standard Proctor Density.
4. Select fill following the SWMP that is free of roots, wood, rock, large stone or foreign material.
5. Prepare the site under the embankment by ripping to at least 100 mm to help bond compacted fill to the existing substrate.
6. Spread the fill in 100 mm to 150 mm layers and compact it at optimum moisture content following the SWMP.
7. Construct the emergency spillway.
8. Rehabilitate the structure following the SWMP.

See Standard Drawing below

EARTH BASIN - WET SD 6-4
(APPLICABLE TO TYPE 'F' AND 'FHD' SITES ONLY)

SANDBAGS OVERLAP ONTO KERB

WIRE OR STEEL MESH (14 GAUGE x 150mm OPE WHERE GEOTEXTILE IS NOT SELF-SUPPORTING)

STAR PICKETS WITH SAFETY CAPS

WOVEN GEOTEXTILE

DROP INLET WITH GRATE

STAF WITH CAP

THREE LAYERS OF SANDBAGS WITH ENDS OVERLAPPED

GAP BETWEEN BAGS ACTS AS SPILLWAY

RUNOFF

RUNOFF

GEOTEXTILE INLET FILTER (SD 6-12) - PERSPECTIVE N.T.S.

SANDBAG SEDIMENT TRAP FOR KERB INLET N.T.S.

STAR PICKETS WITH SAFETY CAPS

WOVEN GEOTEXTILE

DROP INLET WITH GRATE

STAF WITH CAP

GEOTEXTILE INLET FILTER (SD 6-12) - PERSPECTIVE N.T.S.

SANDBAGS PLACED SECURELY AROUND SILL OF DROP INLET

FLOW

GROUND LEVEL AT END OF SANDBAG BARRIER MUST BE HIGHER THAN DROP INLET SANDING LAYER.

THIS SANDBAG LAYER MUST BE HIGHER THAN THE DROP INLET SANDBAG LAYER

SANDBAGS PLACED AND COMPACTED TO PREVENT FLOWS PASSING THROUGH THE BARRIER.

SEDIMENT BARRIER (SD 5-4) DETAIL

Standard drawings

Coir Log Filter

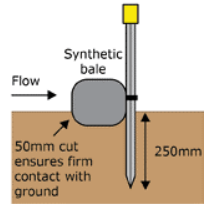

Star pickets / wooden stakes
35mm x 38mm x 900mm min
Minimum 2 per bale

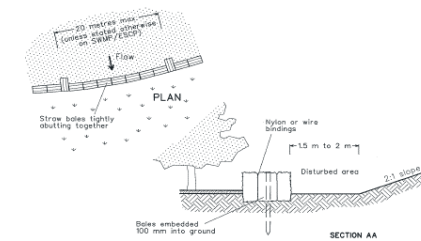
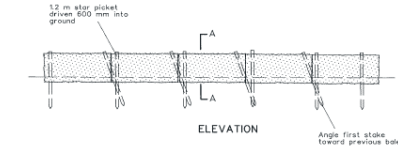
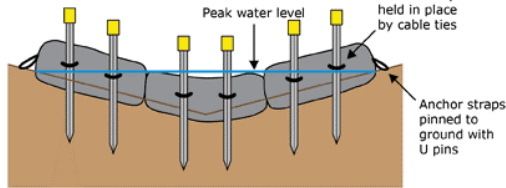

Construction Notes

- Construct the straw bale filter as close as possible to being parallel to the contours of the site.
- Place bales lengthwise in a row with ends tightly abutting. Use straw to fill any gaps between bales. Straws are to be placed parallel to ground.
- Ensure that the maximum height of the filter is one bale.
- Embed each bale in the ground 75 mm to 100 mm and anchor with two 1.2 metre star pickets or stakes. Attach the first star picket or stake to each bale towards the previously laid bale. Drive them 600 mm into the ground and, if possible, flush with the top of the bales. Where star pickets are used and they protrude above the bales, ensure they are fixed with cable ties.
- Where a straw bale filter is constructed downslope from a disturbed batter, ensure the bales are placed 1 to 2 metres downslope from the toe.
- Establish a maintenance program that ensures the integrity of the bales is retained - they could require replacement each two to four months.

STRAW BALE FILTER

SD 6-7

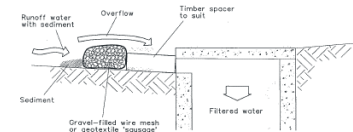
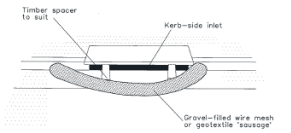

NOTE: This practice only to be used where specified in an approved SWMP/ESCP.

Construction Notes

- Install filters to kerb inlets only at sag points.
- Fabricate a sleeve made from geotextile or wire mesh longer than the length of the inlet pit and fill it with 25 mm to 50 mm gravel.
- Form an elliptical cross-section about 150 mm high x 400 mm wide.
- Place the filter at the opening leaving at least a 100-mm space between it and the kerb inlet. Maintain the opening with spacer blocks.
- Form a seal with the kerb to prevent sediment bypassing the filter.
- Sandbags filled with gravel can substitute for the mesh or geotextile providing they are placed so that they firmly abut each other and sediment-laden waters cannot pass between.

MESH AND GRAVEL INLET FILTER

SD 6-11

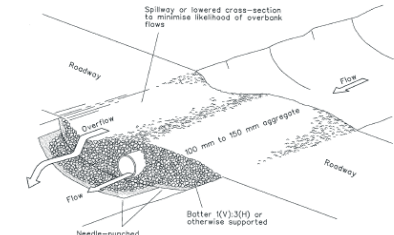

See Standard Drawing below

Construction Notes

- Prohibit all traffic until the access way is constructed.
- Strip any topsoil and place a needle-punched textile over the base of the crossing.
- Place clean, rigid, non polluting aggregate or gravel in the 100 mm to 150 mm size class over the fabric to a minimum depth of 200 mm.
- Provide a 3-metre wide carriageway with sufficient length of culvert pipe to allow less than a 3(H): 1 (V) slope on side batters.
- Install a lower section to act as an emergency spillway in greater than design storm events.
- Ensure that culvert outlets extend beyond the toe of fill embankments.

Short term waterway crossing

SD 5-1

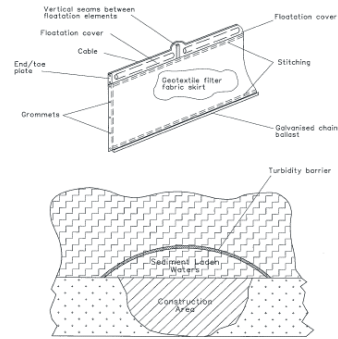

Construction Notes

- Use turbidity barriers only where high flows are unlikely to remove accumulated sediment and/or move the curtain significantly.
- Where the barrier is to remain in place for more than one month, ensure the floatation cover is a UV-resistant, durable material.
- Use only closed cell foam or foam-filled PVC piping as floatation elements. Do not use unfilled pipes.
- Use only woven or heat-set non woven geotextiles. Needle-punched, non woven geotextiles can become fouled with debris that fray and delaminate them as they move with the waves or currents.
- Remove captured sediment before the barrier is decommissioned.
- In tidal areas, ensure the barrier can rise and fall without being moved from its position.

TURBIDITY BARRIER

SD 6-10

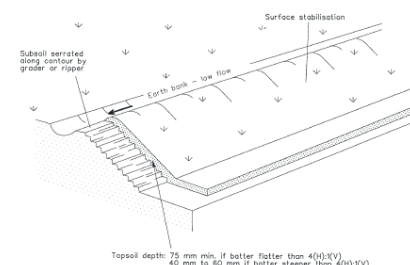

Construction Notes

- Scarify the ground surface along the line of the contour to a depth of 50 mm to 100 mm to break up any hardsetting surfaces and to provide a good bond between the respread material and subsoil.
- Add soil ameliorants as required by the ESCP or SWMP.
- Rip to a depth of 300 mm if compacted layers occur.
- Where possible, replace topsoil to a depth of 40 to 60 mm on lands where the slope exceeds 4(H):1(V) and to at least 75 mm on lower gradients.

REPLACING TOPSOIL

SD 4-2

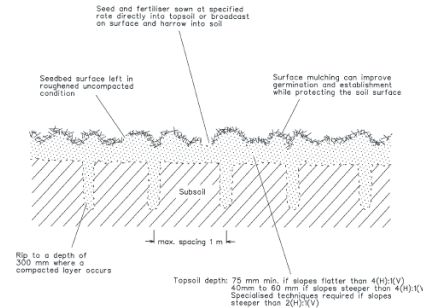

Construction Notes

- Loosen compacted soil before sowing any seed. If necessary, rip the soil to a depth of 300 mm. Avoid rotary hoe cultivation.
- Work the ground only as much as necessary to achieve the desired tillth and prepare a good seedbed.
- Avoid cultivation in very wet or very dry conditions.
- Cultivate on or close to the contour where possible, not up and down the slope.

SEEDBED PREPARATION

SD 7-1

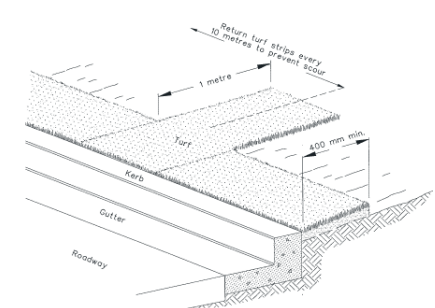

Construction Notes

- Install a 400-mm minimum wide roll of turf on the footpath next to the kerb and at the same level as the top of the kerb.
- Lay 1.4 metre long turf strips normal to the kerb every 10 metres.
- Rehabilitate disturbed soil behind the

KERBSIDE TURF STRIP

SD 6-13

Standard drawings

Construction Notes

- Place stockpiles more than 2 (preferably 5) metres from existing vegetation, concentrated water flow, roads and hazard areas.
- Construct on the contour as low, flat, elongated mounds.
- Where there is sufficient area, topsoil stockpiles shall be less than 2 metres in height.
- Where they are to be in place for more than 10 days, stabilise following the approved ESCP or SWMP to reduce the C-factor to less than 0.10.
- Construct earth banks (Standard Drawing 5-5) on the upslope side to divert water around stockpiles and sediment fences (Standard Drawing 6-8) 1 to 2 metres downslope.

STOCKPILES SD 4-1

Construction Notes

- Remove any rocks, clods, sticks or grass from the ground surface before laying the matting.
- Spread topsoil to at least 75 mm depth.
- Where appropriate, complete fertilising and seeding on a properly prepared seedbed (Standard Drawing 7-1) before laying the matting.
- Ensure the fabric can be continuously in contact with the soil by grading the surface carefully first.
- Lay the matting in "shingle-fashion" with the ends of each upstream roll overlapping the next roll downslope.
- Ensure sufficient stakes are used to maintain a good contact between the soil and the matting.

RECP : SHEET FLOW SD 5-2

Construction Notes

- Remove any rocks, clods, sticks or grass from the surface before laying matting
- Ensure that topsoil is at least 75 mm deep.
- Complete fertilising and seeding before laying the matting.
- Ensure fabric will be continuously in contact with the soil by grading the surface carefully first.
- Lay the fabric in "shingle-fashion", with the end of each upstream roll overlapping those downstream. Ensure each roll is anchored properly at its upslope end (Standard Drawing 5-7b).
- Ensure that the full width of flow in the channel is covered by the matting up to the design storm event, usually in the 10-year ARI time of concentration storm event.
- Divert water from the structure until vegetation is stabilised properly.

RECP : CONCENTRATED FLOW SD 5-7

Construction Notes

- Check dams can be built with various materials, including rocks, logs, sandbags and straw bales. The maintenance program should ensure their integrity is retained, especially where constructed with straw bales. In the case of bales, this might require their replacement each two to four months.
- Trench the check dam 200 mm into the ground across its whole width. Where rock is used, fill the trenches to at least 100 mm above the ground surface to reduce the risk of undercutting.
- Normally, their maximum height should not exceed 600 mm above the gully floor. The centre should act as a spillway, being at least 150 mm lower than the outer edges.
- Space the dams so the top of the upstream dam is level with the spillway of the next downstream dam.

ROCK CHECK DAM SD 5-4

Construction Notes

- Build with gradients between 1 percent and 5 percent.
- Avoid removing trees and shrubs if possible - work around them.
- Ensure the structures are free of projections or other irregularities that could impede water flow.
- Build the drains with circular, parabolic or trapezoidal cross sections, not V shaped.
- Ensure the banks are properly compacted to prevent failure.
- Complete permanent or temporary stabilisation within 10 days of construction.

EARTH BANK (LOW FLOW) SD 5-5

Construction Notes

- Construct at the gradient specified on the ESCP or SWMP, normally between 1 and 5 percent.
- Avoid removing trees and shrubs if possible - work around them.
- Ensure the structures are free of projections or other irregularities that could impede water flow.
- Build the drains with circular, parabolic or trapezoidal cross sections, not V-shaped, at the dimensions shown on the SWMP.
- Ensure the banks are properly compacted to prevent failure.
- Complete permanent or temporary stabilisation within 10 days of construction following Table 5.2 in Landcom (2004).
- Where discharging to erodible lands, ensure they outlet through a properly constructed level spreader.
- Construct the level spreader at the gradient specified on the ESCP or SWMP, normally less than 1 percent or level.
- Where possible, ensure they discharge waters onto either stabilised or undisturbed disposal sites within the same subcatchment area from which the water originated. Approval might be required to discharge into other subcatchments.

EARTH BANK (HIGH FLOWS) SD 5-6

Stabilised topsoil diversion bank

Construction Notes

- Construct with gradient of 1% to 5%.
- Avoid removing trees and shrubs if possible - work around them.
- Drains to be circular, parabolic or trapezoidal cross section not V-shaped.
- Earth bank to be adequately compacted in order to prevent failure.
- Permanent or temporary stabilisation of the earth bank to be completed within 10 days of construction.
- All outlets from disturbed lands are to be fed into a sediment basin or similar discharge runoff collection from undisturbed lands onto either a stabilised or an undisturbed disposal site within the same subcatchment area from which the water originated.
- Compact bank with a suitable implement in situations where they are required to function for more than five days.
- Earth bank to be free of projections or other irregularities that will impede normal flow.

EARTH BANK (ONSITE & OFFSITE COMBINED) SD 5-7

Construction Notes

- CONSTRUCT WITH GRADIENT OF 1% TO 5%.
- AVOID REMOVING TREES AND SHRUBS IF POSSIBLE - WORK AROUND THEM.
- DRAINS TO BE CIRCULAR, PARABOLIC OR TRAPEZOIDAL CROSS SECTION NOT V-SHAPED.
- EARTH BANK TO BE ADEQUATELY COMPACTED IN ORDER TO PREVENT FAILURE.
- PERMANENT OR TEMPORARY STABILISATION OF THE EARTH BANK TO BE COMPLETED WITHIN 10 DAYS OF CONSTRUCTION.
- ALL OUTLETS FROM DISTURBED LANDS ARE TO BE FED INTO A SEDIMENT BASIN OR SIMILAR DISCHARGE RUNOFF COLLECTION FROM UNDISTURBED LANDS ONTO EITHER A STABILISED OR AN UNDISTURBED DISPOSAL SITE WITHIN THE SAME SUBCATCHMENT AREA FROM WHICH THE WATER ORIGINATED.
- COMPACT BANK WITH A SUITABLE IMPLEMENT IN SITUATIONS WHERE THEY ARE REQUIRED TO FUNCTION FOR MORE THAN FIVE DAYS.
- EARTH BANK TO BE FREE OF PROJECTIONS OR OTHER IRREGULARITIES THAT WILL IMPEDE NORMAL FLOW.

OFFSITE WATER DRAIN SD 5-8

Standard drawings

ENERGY DISSIPATER SD 5-8

Construction Notes

1. Compact the subgrade fill to the density of the surrounding undisturbed material.
2. Prepare a smooth, even foundation for the structure that will ensure that the needle-punched geotextile does not sustain serious damage when covered with rock.
3. Should any minor damage to the geotextile occur, repair it before spreading any aggregate. For repairs, patch one piece of fabric over the damage, making sure that all joints and patches overlap more than 300 mm.
4. Lay rock following the drawing, according to Table 5.2 of Lansdon (2004) and with a minimum diameter of 75 mm.
5. Ensure that any concrete or riprap used for the energy dissipater or the outlet protection conforms to the grading limits specified on the SWMP.

STABILISED SITE ACCESS SD 6-14

Construction Notes

1. Strip the topsoil, level the site and compact the subgrade.
2. Cover the area with needle-punched geotextile.
3. Construct a 200-mm thick pad over the geotextile using road base or 30-mm aggregate.
4. Ensure the structure is at least 15 metres long or to building alignment and at least 3 metres wide.
5. Where a sediment fence joins onto the stabilised access, construct a hump in the stabilised access to divert water to the sediment fence.

SEDIMENT FENCE SD 6-8

Construction Notes

1. Construct sediment fences as close as possible to being parallel to the contours of the site, but with small returns as shown in the drawing to limit the catchment area of any one section. The catchment area should be small enough to limit water flow if concentrated at one point to 50 litres per second in the design storm event, usually the 10-year event.
2. Cut a 150-mm deep trench along the upslope line of the fence for the bottom of the fabric to be entrenched.
3. Drive 1.5 metre long star pickets into ground at 2.5 metre intervals (max) at the downslope edge of the trench. Ensure any star pickets are fixed with safety caps.
4. Fix self-supporting geotextile to the upslope side of the posts ensuring it goes to the base of the trench. Fix the geotextile with wire ties or as recommended by the manufacturer. Only use geotextile specifically produced for sediment fencing. The use of shade cloth for this purpose is not satisfactory.
5. Join sections of fabric at a support post with a 150-mm overlap.
6. Backfill the trench over the base of the fabric and compact it thoroughly over the geotextile.

ALTERNATIVE SEDIMENT FENCE SD 6-9

Construction Notes

1. Install this type of sediment fence when use of support posts is not desirable or not possible. Such conditions might apply, for example, where approval is granted from the appropriate authorities to place these fences in highly sensitive estuarine areas.
2. Use bent trench mesh to support the F82 welded mesh facing as shown on the drawing above. Attach the geotextile to the welded mesh facing using UV resistant cable ties.
3. Stabilise the whole structure with sandbag or rock anchoring over the trench mesh and the leading edge of the geotextile. The anchoring should be sufficiently large to ensure stability of the structure in the design storm event, usually the 10 year event.

EARTH BASIN - WET SD 6-4

Construction Notes

1. Remove all vegetation and topsoil from under the dam wall and from within the storage area.
2. Construct a cut-off trench 500 mm deep and 1,200 mm wide along the centre-line of the embankment extending to a point on the gully wall level with the rear crest.
3. Maintain the trench free of water and recompact the materials with equipment as specified in the SWMP to 95 per cent Standard Proctor Density.
4. Select fill following the SWMP that is free of roots, wood, rock, large stone or foreign material.
5. Prepare the site under the embankment by ripping to at least 100 mm to help bond compacted fill to the existing substrate.
6. Spread the fill in 100 mm to 150 mm layers and compact it at optimum moisture content following the SWMP.
7. Construct the emergency spillway.
8. Rehabilitate the structure following the SWMP.

See Standard Drawing below

SANDBAG SEDIMENT TRAP FOR KERB INLET N.T.S.

GEOTEXTILE INLET FILTER (SD 6-12) - PERSPECTIVE N.T.S.

SEDIMENT BARRIER (SD 5-4) DETAIL

Standard drawings

Coir Log Filter

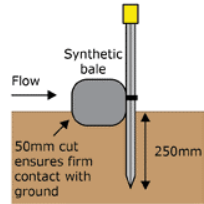

Star pickets / wooden stakes
35mm x 38mm x 900mm min
Minimum 2 per bale

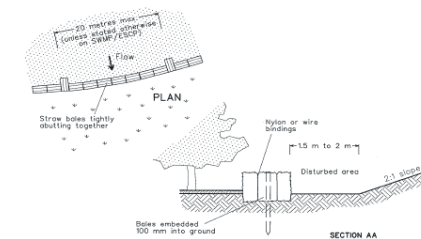
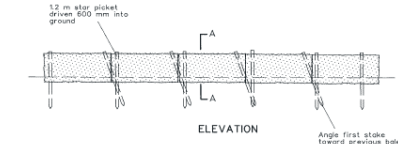
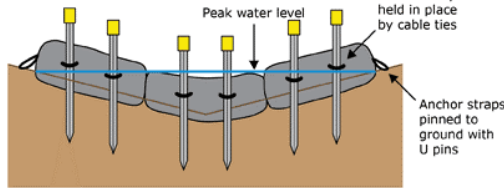

- Construction Notes**
- Construct the straw bale filter as close as possible to being parallel to the contours of the site.
 - Place bales lengthwise in a row with ends tightly abutting. Use straw to fill any gaps between bales. Straws are to be placed parallel to ground.
 - Ensure that the maximum height of the filter is one bale.
 - Embed each bale in the ground 75 mm to 100 mm and anchor with two 1.2 metre star pickets or stakes. Attach the first star picket or stake to each bale towards the previously laid bale. Drive them 600 mm into the ground and, if possible, flush with the top of the bales. Where star pickets are used and they protrude above the bales, ensure they are fixed with caps.
 - Where a straw bale filter is constructed downslope from a disturbed batter, ensure the bales are placed 1 to 2 metres downslope from the toe.
 - Establish a maintenance program that ensures the integrity of the bales is retained - they could require replacement each two to four months.

STRAW BALE FILTER SD 6-7

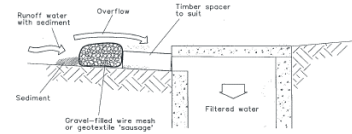
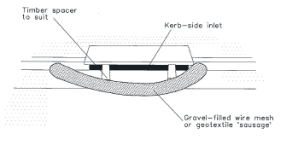

NOTE: This practice only to be used where specified in an approved SWMP/ESCP.

- Construction Notes**
- Install filters to kerb inlets only at sag points.
 - Fabricate a sleeve made from geotextile or wire mesh longer than the length of the inlet pit and fill it with 25 mm to 50 mm gravel.
 - Form an elliptical cross-section about 150 mm high x 400 mm wide.
 - Place the filter at the opening leaving at least a 100-mm space between it and the kerb inlet. Maintain the opening with spacer blocks.
 - Form a seal with the kerb to prevent sediment bypassing the filter.
 - Sandbags filled with gravel can substitute for the mesh or geotextile providing they are placed so that they firmly abut each other and sediment-laden waters cannot pass between.

MESH AND GRAVEL INLET FILTER SD 6-11

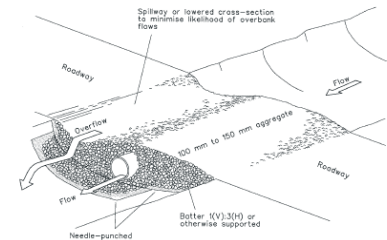

See Standard Drawing below

- Construction Notes**
- Prohibit all traffic until the access way is constructed.
 - Strip any topsoil and place a needle-punched textile over the base of the crossing.
 - Place clean, rigid, non polluting aggregate or gravel in the 100 mm to 150 mm size class over the fabric to a minimum depth of 200 mm.
 - Provide a 3-metre wide carriageway with sufficient length of culvert pipe to allow less than a 3(H): 1 (V) slope on side batters.
 - Install a lower section to act as an emergency spillway in greater than design storm events.
 - Ensure that culvert outlets extend beyond the toe of fill embankments.

Short term waterway crossing SD 5-1

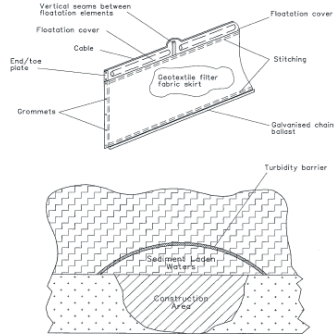

- Construction Notes**
- Use turbidity barriers only where high flows are unlikely to remove accumulated sediment and/or move the curtain significantly.
 - Where the barrier is to remain in place for more than one month, ensure the floatation cover is a UV-resistant, durable material.
 - Use only closed cell foam or foam-filled PVC piping as floatation elements. Do not use unfilled pipes.
 - Use only woven or heat-set non woven geotextiles. Needle-punched, non woven geotextiles can become fouled with debris that fray and destabilize them as they move with the waves or currents.
 - Remove captured sediment before the barrier is decommissioned.
 - In tidal areas, ensure the barrier can rise and fall without being moved from its position.

TURBIDITY BARRIER SD 6-10

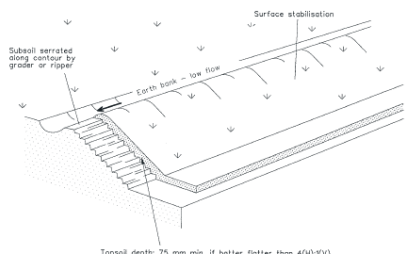

- Construction Notes**
- Scarify the ground surface along the line of the contour to a depth of 50 mm to 100 mm to break up any hardsetting surfaces and to provide a good bond between the respread material and subsoil.
 - Add soil ameliorants as required by the ESCP or SWMP.
 - Rip to a depth of 300 mm if compacted layers occur.
 - Where possible, replace topsoil to a depth of 40 to 60 mm on lands where the slope exceeds 4(H):1(V) and to at least 75 mm on lower gradients.

REPLACING TOPSOIL SD 4-2

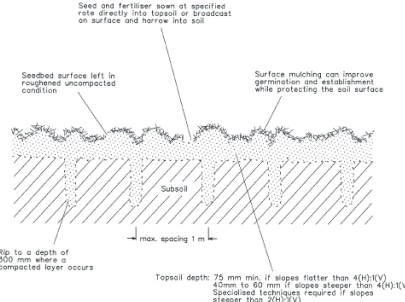

- Construction Notes**
- Loosen compacted soil before sowing any seed. If necessary, rip the soil to a depth of 300 mm. Avoid rotary hoe cultivation.
 - Work the ground only as much as necessary to achieve the desired tilth and prepare a good seedbed.
 - Avoid cultivation in very wet or very dry conditions.
 - Cultivate on or close to the contour where possible, not up and down the slope.

SEEDBED PREPARATION SD 7-1

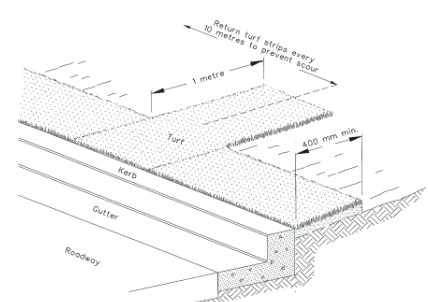

- Construction Notes**
- Install a 400-mm minimum wide roll of turf on the footpath next to the kerb and at the same level as the top of the kerb.
 - Lay 1.4 metre long turf strips normal to the kerb every 10 metres.
 - Rehabilitate disturbed soil behind the

KERBSIDE TURF STRIP SD 6-13

Appendix G

Standard drawings

Standard drawings

Construction Notes

- Place stockpiles more than 2 (preferably 5) metres from existing vegetation, concentrated water flow, roads and hazard areas.
- Construct on the contour as low, flat, elongated mounds.
- Where there is sufficient area, topsoil stockpiles shall be less than 2 metres in height.
- Where they are to be in place for more than 10 days, stabilise following the approved ESCP or SWMP to reduce the C-factor to less than 0.10.
- Construct earth banks (Standard Drawing 4-5) on the upslope side to divert water around stockpiles and sediment fences (Standard Drawing 6-8) 1 to 2 metres downslope.

STOCKPILES **SD 4-1**

Construction Notes

- Remove any rocks, clods, sticks or grass from the ground surface before laying the matting.
- Spread topsoil to at least 75 mm depth.
- Where appropriate, complete fertilising and seeding on a properly prepared seedbed (Standard Drawing 7-1) before laying the matting.
- Ensure the fabric can be continuously in contact with the soil by grading the surface carefully first.
- Lay the matting in a "single-fashion" with the ends of each upstream roll overlapping the next roll downstream.
- Ensure sufficient staples are used to maintain a good contact between the soil and the matting.

RECP: SHEET FLOW **SD 5-2**

Construction Notes

- Remove any rocks, clods, sticks or grass from the surface before laying matting.
- Ensure that topsoil is at least 75 mm deep.
- Complete fertilising and seeding before laying the matting.
- Ensure fabric will be continuously in contact with the soil by grading the surface carefully first.
- Lay the fabric in a "single-fashion", with the end of each upstream roll overlapping those downstream. Ensure each roll is anchored properly at its upslope end (Standard Drawing 5-7).
- Ensure that the full width of flow in the channel is covered by the matting up to the design storm event, usually in the 10-year ARI time of concentration storm event.
- Divert water from the structure until vegetation is stabilised properly.

RECP: CONCENTRATED FLOW **SD 5-7**

Construction Notes

- Check dams can be built with various materials, including rocks, logs, sandbags and straw bales. The maintenance program should ensure their integrity is retained, especially where constructed with straw bales. In the case of bales, this might require their replacement each two to four months.
- Trench the check dam 200 mm into the ground across its whole width. Where rock is used, fill the trenches to at least 100 mm above the ground surface to reduce the risk of undercutting.
- Normally, their maximum height should not exceed 600 mm above the gully floor. The centre should act as a spillway, being at least 150 mm lower than the outer edges.
- Space the dams so the top of the upslope dam is level with the spillway of the next downstream dam.

ROCK CHECK DAM **SD 5-4**

Construction Notes

- Build with gradients between 1 percent and 5 percent.
- Avoid removing trees and shrubs if possible - work around them.
- Ensure the structures are free of projections or other irregularities that could impede water flow.
- Build the drains with circular, parabolic or trapezoidal cross sections, not V-shaped.
- Ensure the banks are properly compacted to prevent failure.
- Complete permanent or temporary stabilisation within 10 days of construction.

EARTH BANK (LOW FLOW) **SD 5-5**

Construction Notes

- Construct at the gradient specified on the ESCP or SWMP, normally between 1 and 5 percent.
- Avoid removing trees and shrubs if possible - work around them.
- Ensure the structures are free of projections or other irregularities that could impede water flow.
- Build the drains with circular, parabolic or trapezoidal cross sections, not V-shaped, at the dimensions shown on the SWMP.
- Ensure the banks are properly compacted to prevent failure.
- Complete permanent or temporary stabilisation within 10 days of construction following Table 5.2 in Landcom (2004).
- Where discharging to erodible lands, ensure they outlet through a properly constructed level spreader.
- Construct the level spreader at the gradient specified on the ESCP or SWMP, normally less than 1 percent or level.
- Where possible, ensure they discharge waters onto either stabilised or undisturbed disposal sites within the same subcatchment area from which the water originated. Approval might be required to discharge into other subcatchments.

EARTH BANK (HIGH FLOWS) **SD 5-6**

Construction Notes

- Construct with gradient of 1% to 5%.
- Avoid removing trees and shrubs if possible - work around them.
- Drains to be circular, parabolic or trapezoidal cross section not V-shaped.
- Earth bank to be adequately compacted in order to prevent failure.
- Permanent or temporary stabilisation of the earth bank to be completed within 10 days of construction.
- All outlets from disturbed lands are to be fed into a sediment basin or similar.
- Discharge runoff collection from undisturbed lands onto either a stabilised or an undisturbed disposal site within the same subcatchment area from which the water originated.
- Compact bank with a suitable implement in situations where they are required to function for more than five days.
- Earth bank to be free of projections or other irregularities that will impede normal flow.

Stabilised topsoil diversion bank

EARTH BANK (ONSITE & OFFSITE COMBINED) **SD 5-6**

Construction Notes

- CONSTRUCT WITH GRADIENT OF 1% TO 5%.
- Avoid removing trees and shrubs if possible - work around them.
- Drains to be circular, parabolic or trapezoidal cross section not V-shaped.
- Earth bank to be adequately compacted in order to prevent failure.
- Permanent or temporary stabilisation of the earth bank to be completed within 10 days of construction.
- All outlets from disturbed lands are to be fed into a sediment basin or similar.
- Discharge runoff collection from undisturbed lands onto either a stabilised or an undisturbed disposal site within the same subcatchment area from which the water originated.
- Compact bank with a suitable implement in situations where they are required to function for more than five days.
- Earth bank to be free of projections or other irregularities that will impede normal flow.

OFFSITE WATER DRAIN **SD 5-4**

Standard drawings

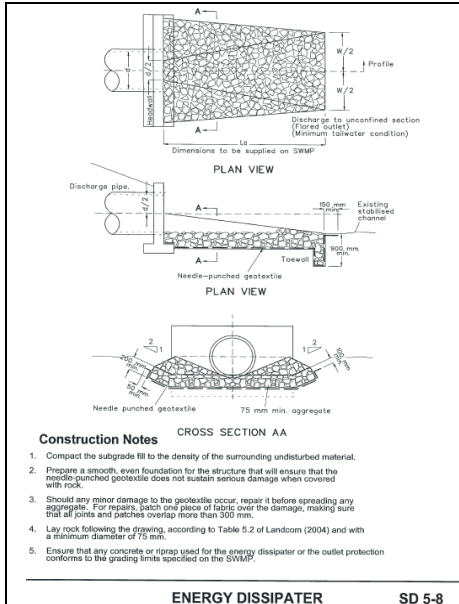

ENERGY DISSIPATOR

SD 5-8

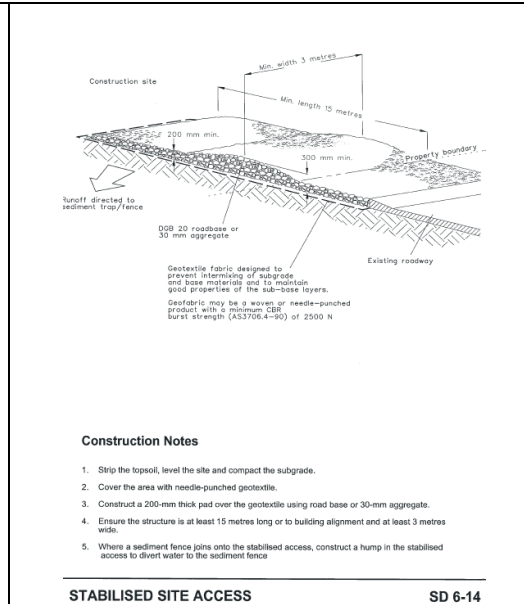

STABILISED SITE ACCESS

SD 6-14

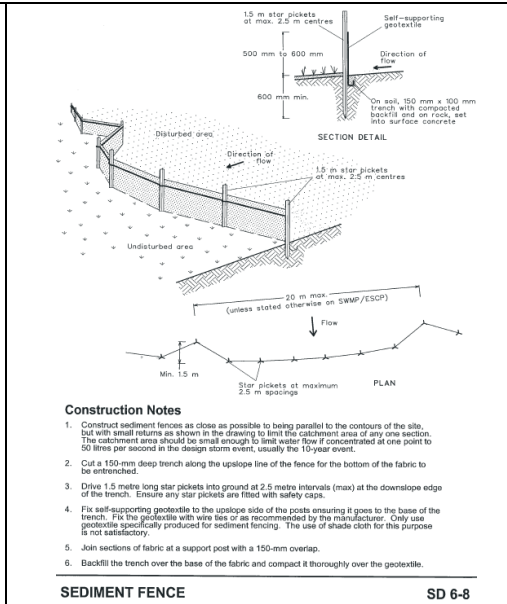

SEDIMENT FENCE

SD 6-8

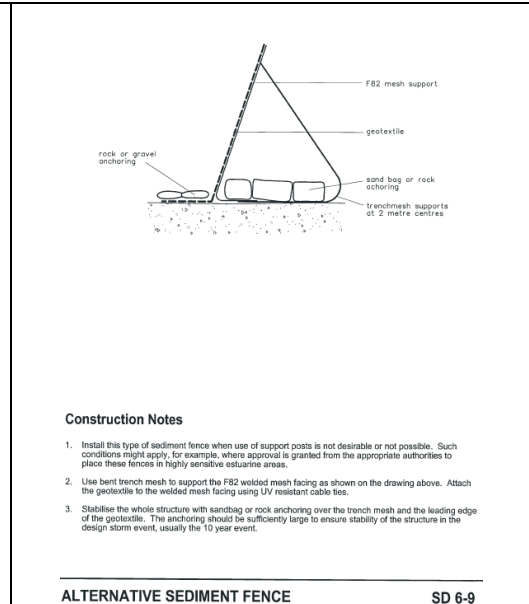

ALTERNATIVE SEDIMENT FENCE

SD 6-9

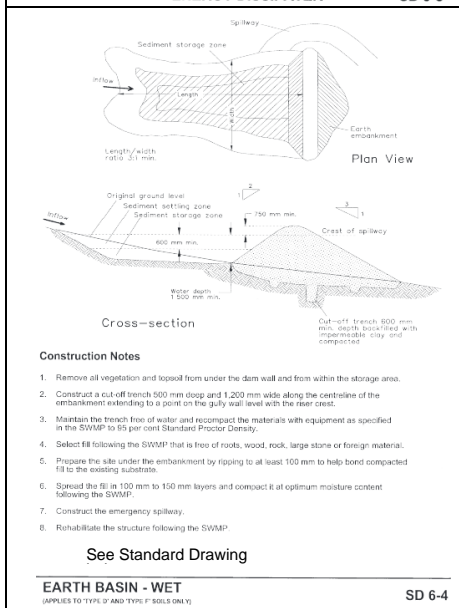

SD 6-4

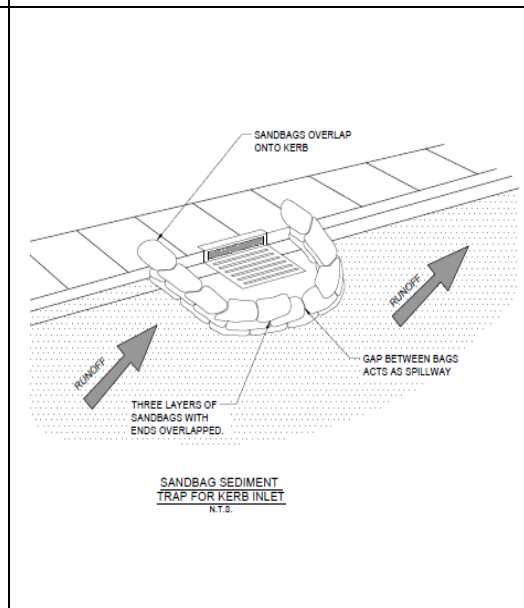

GEOTEXTILE INLET FILTER (SD 6-12) - PERSPECTIVE
N.T.S.

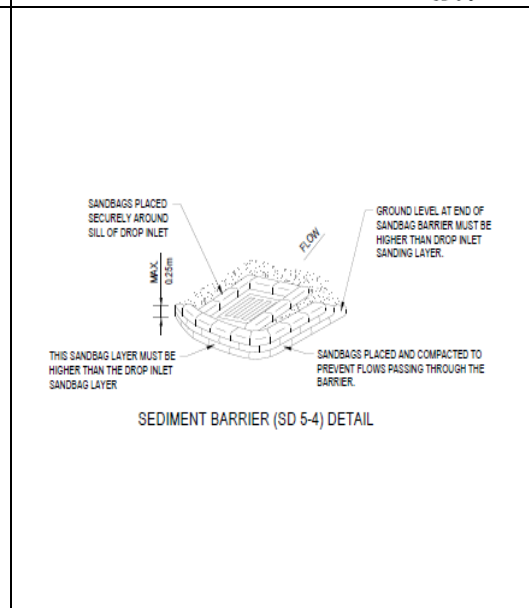

SEDIMENT BARRIER (SD 6-4) DETAIL

Standard drawings

Coir Log Filter

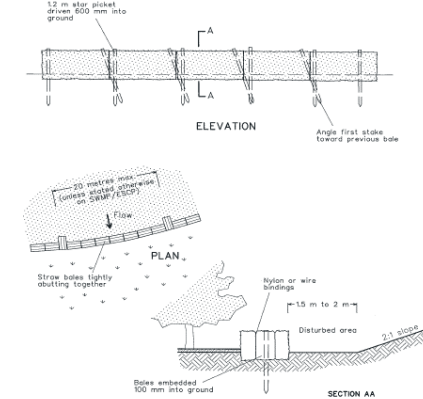
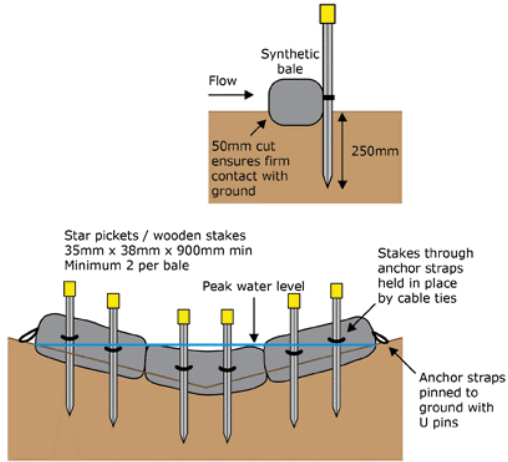

Construction Notes

1. Construct the straw bale filter as close as possible to being parallel to the contours of the site.
2. Place bales lengthwise in a row with ends tightly abutting. Use straw to fill any gaps between bales. Straws ends to be placed parallel to ground.
3. Ensure that the maximum height of the filter is one bale.
4. Embed each bale in the ground 75 mm to 100 mm and anchor with two 1.2 metre star pickets or stakes. Angle the first star picket or stake in each bale towards the previously laid bale. Drive them 100 mm into the ground and, if possible, flush with the top of the bales. Where star pickets are used and they protrude above the bales, ensure they are fixed with safety caps.
5. Where a straw bale filter is constructed downslope from a disturbed batter, ensure the bales are placed 1 to 2 metres downslope from the toe.
6. Establish a maintenance program that ensures the integrity of the bales is retained - they could require replacement each two to four months.

STRAW BALE FILTER

SD 6-7

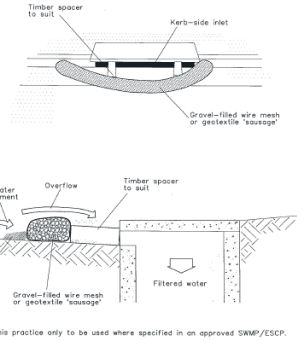

NOTE: This practice only to be used where specified in an approved SWMP/ESCP.

Construction Notes

1. Install filters to kerb inlets only at sag points.
2. Fabricate a sleeve made from geotextile or wire mesh longer than the length of the inlet pit and fill it with 25 mm to 50 mm gravel.
3. Form an elliptical cross-section about 150 mm high x 400 mm wide.
4. Place the filter at the opening leaving at least a 100-mm space between it and the kerb inlet. Maintain the opening with spacer blocks.
5. Form a seal with the kerb to prevent sediment bypassing the filter.
6. Sandbags filled with gravel can substitute for the mesh or geotextile providing they are placed so that they firmly abut each other and sediment-laden waters cannot pass between.

MESH AND GRAVEL INLET FILTER

SD 6-11

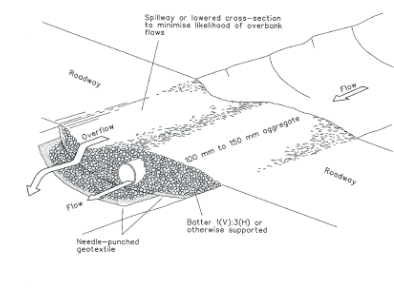

See Standard Drawing below

Construction Notes

1. Prohibit all traffic until the access way is constructed.
2. Strip any topsoil and place a needle-punched textile over the base of the crossing.
3. Place clean, rigid, non polluting aggregate or gravel in the 100 mm to 150 mm size class over the fabric to a minimum depth of 200 mm.
4. Provide a 3-metre wide carriageway with sufficient length of culvert pipe to allow less than 0.3(H): 1 (V) slope on side batters.
5. Install a lower section to act as an emergency spillway in greater than design storm events.
6. Ensure that culvert outlets extend beyond the toe of fill embankments.

Short term waterway crossing

SD 5-1

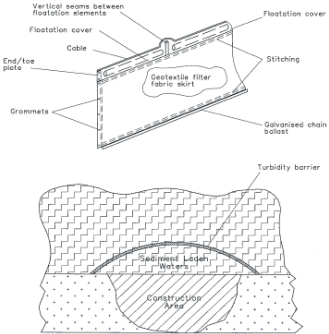

Construction Notes

1. Use turbidity barriers only where high flows are unlikely to remove accumulated sediment and/or move the curtain significantly.
2. Where the barrier is to remain in place for more than one month, ensure the floatation cover is a UV-resistant, durable material.
3. Use only closed cell foam or foam-filled PVC piping as floatation elements. Do not use unfilled pipes.
4. Use only woven or heat-set non woven geotextiles. Needle-punched, non woven geotextiles can become fouled with debris that fry and sedimentate them as they move with the waves or currents.
5. Remove captured sediment before the barrier is decommissioned.
6. In tidal areas, ensure the barrier can rise and fall without being moved from its position.

TURBIDITY BARRIER

SD 6-10

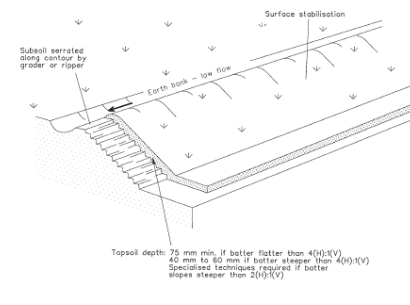

Construction Notes

1. Scarify the ground surface along the line of the contour to a depth of 50 mm to 100 mm to break up any hardsetting surfaces and to provide a good bond between the respread material and subsoil.
2. Add soil ameliorants as required by the ESCP or SWMP.
3. Rip to a depth of 300 mm if compacted layers occur.
4. Where possible, replace topsoil to a depth of 40 to 60 mm on lands where the slope exceeds 4(H):1(V) and to at least 75 mm on lower gradients.

REPLACING TOPSOIL

SD 4-2

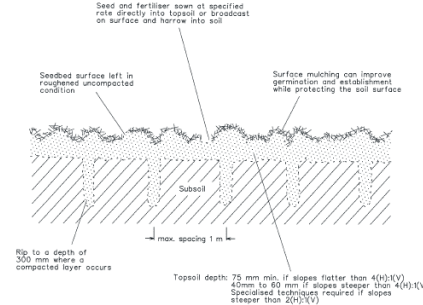

Construction Notes

1. Loosen compacted soil before sowing any seed. If necessary, rip the soil to a depth of 300 mm. Avoid rotary hoe cultivation.
2. Work the ground only as much as necessary to achieve the desired flth and prepare a good seedbed.
3. Avoid cultivation in very wet or very dry conditions.
4. Cultivate on or close to the contour where possible, not up and down the slope.

SEEDBED PREPARATION

SD 7-1

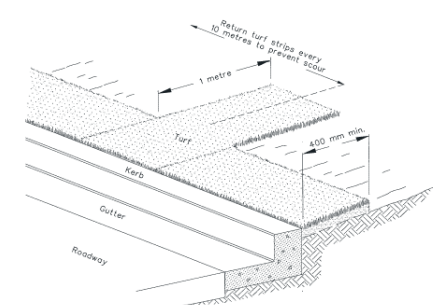

Construction Notes

1. Install a 400-mm minimum wide roll of turf on the footpath next to the kerb and at the same level as the top of the kerb.
2. Lay 1.4 metre long turf strips normal to the kerb every 10 metres.
3. Rehabilitate disturbed soil behind the

KERBSIDE TURF STRIP

SD 6-13

Appendix C – Water Quality Management Manual



Water Quality Management Manual

PM-PLA-014

9 June 2023

Contents

Water Quality Management Manual

1	Introduction	1
1.1	What is Erosion.....	1
1.2	What is Sediment.....	1
1.3	The Importance of Erosion and Sediment Control.....	2
1.4	Legal Obligations	2
1.5	Duty to Notify	2
1.6	Offences including “Potential for Environmental Harm”	2
1.7	Regulation and Enforcement Monitoring	3
1.8	Strategizing for Compliance with Legislation	4
1.9	Purpose of this Document.....	4
2	Water Discharge Quality	6
2.1	Discharge Limits	6
2.2	Coarse Sediment	6
2.3	Fine Sediment (Total Suspended Solids).....	6
2.4	Turbidity.....	7
2.5	Acidity or Alkalinity (pH).....	7
3	Erosion and Sediment Control (ESC) Planning	8
3.1	Calculating Erosion Risk	8
3.2	Priority of Controls	8
3.3	Types of Controls.....	9
4	Sediment Fencing	9
4.1	Description.....	9
4.2	Establishment	9
4.3	Monitoring.....	11
5	Stockpiling	12
5.1	Description.....	12
5.2	Establishment	13
5.3	Monitoring.....	13
6	Up-Slope Water Diversions	14
6.1	Description.....	14
6.2	Establishment	14
6.3	Monitoring.....	15

7	Drainage Channels	16
7.1	Description.....	16
7.2	Establishment.....	17
7.3	Chutes at Outflow.....	18
7.4	Monitoring.....	19
8	Sumps and Sediment Traps	20
8.1	Description.....	20
8.2	Monitoring.....	22
9	Sediment Basins	23
9.1	Description.....	23
9.2	Establishment (Type D).....	24
9.3	High Efficiency Sediment Basins (aka Auto-Dosing, Type A/B).....	26
9.4	Monitoring and Servicing.....	30
9.5	Reducing Turbidity for Discharge.....	30
9.6	Reducing pH for Discharge.....	31
9.7	Protocol for Discharging.....	31
9.8	Decommissioning.....	32
9.9	Monitoring.....	Error! Bookmark not defined.
10	Vehicle Entry and Exit Grids	33
10.1	Description.....	33
10.2	Establishment.....	35
10.3	Monitoring.....	35
11	Concrete Washouts	37
11.1	Description.....	37
11.2	Establishment.....	37
11.3	Monitoring.....	38
12	Wet Trade Backwash	40
12.1	Paint and Plaster Washouts.....	40
12.2	Sawcutting Backwash.....	41
13	Protection of Stormwater Infrastructure	42
13.1	Description.....	42
13.2	Establishment.....	42
13.3	Monitoring.....	45
14	Grass/Turf Buffer zones	46
14.1	Description.....	46
14.2	Establishment.....	46
14.3	Monitoring.....	46

15	Erosion Protection and Dust Control	47
15.1	Water Carts	47
15.2	Road Base	47
15.3	Soil Surfactants/Bio-Polymer Membrane.....	47
15.4	Erosion Protection	48
15.5	Sprinklers.....	48
16	Working In And Around Watercourses	49
16.1	Description.....	49
16.2	Establishment	49
16.3	Monitoring.....	49
17	Emergency Inundation	50
17.1	Storm events.....	50
17.2	In-Situ Flocculation and Pumping.....	50
17.3	Localised Sump Pits	51
17.4	Liquid Waste Disposal	52
17.5	Trade Waste Agreements	52
18	Chemical Storage	53
19	Water Quality Testing	54
19.1	Operation.....	54
19.2	Testing Intervals	54
19.3	Test Points.....	54
20	Phases of the works	56
20.1	Clearing and Rehabilitation	56
20.2	Operation.....	56
20.3	Site Closure	57
21	Soil Characteristics	58
21.1	Alluvium	59
21.2	Clay (Cohesive soils)	59
21.3	Sand (Granular soils).....	59
21.4	Indurated Sands (Coffee Rock).....	59
21.5	Loam	59
21.6	Topsoil.....	59
21.7	Fill.....	59
21.8	Acid Sulfate	60
21.9	Iron and Aluminium Concentration	61
22	Groundwater Management	62
22.1	Dewatering	62
22.2	Heavy Metals	62

22.3 Acid Sulfate Groundwater	63
22.4 Groundwater Expression	63
23 Environmental Constraints	64
23.1 Erosion Hazard	64
23.2 Staging	64
23.3 Season and Climate.....	64
23.4 Proximity to Waterways	64
23.5 Controls outside of Site	64
24 Bibliography	65
24.1 References	65
24.2 Images.....	65
24.3 Disclaimer.....	67

1 Introduction

1.1 What is Erosion

Erosion is the process by which soil or rock is displaced by external forces, whether caused by nature or human activities such as construction. It is a natural process, and in a homeostatic environment, erosion will replenish at roughly the same rate the soil is eroded. However, human actions such as unsustainable use of land and construction have accelerated the erosion process. During excessive rainfall and windstorms, the effect is compounded, and larger amounts of soil can be detached and transported.

Research in Queensland by Healthy Waterways.org suggests that up to 80% of the sediment discharged on any given plot of land will occur during construction. This is because of the unnatural volume of traffic and earthworks that exposes soil to weather, allowing easy dispersion by rainfall.

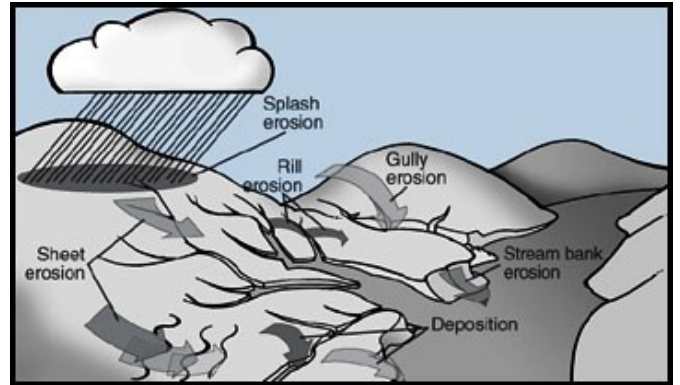

1.2 What is Sediment

Sediment is the material that is released from the process of weathering and erosion, displaced by weather such as wind or water.

Sediment can come in variously particles sizes depending on factors such as the impact/type of erosion (e.g. raindrop vs excavator bucket), and the dispersivity of the soil (i.e. how easy is to break up and displace).

The particle sizes each present various problems and control measures have to take into account the differing nature of each.



Particle Size – Turbidity vs Sediment

1.3 The Importance of Erosion and Sediment Control

There is a long list of impacts resulting from the unnatural release of erosion and sediment. The key list of direct impacts includes:

- Turbid water reduces the ability of light to penetrate, stifling plant growth. An imperceptibly small increase in turbidity can dramatically reduce plant life.
- Sediment can scour algae from stream beds and coupled with an over-abundance of nutrients from reduced plant life, can create algal blooms and fish-kills.
- Suspended sediment can clog fish gills, and in some cases, sediment can completely smother bottom-dwellers. It can also displace habitats and reduce marine food sources.
- Drains and sewer systems can become blocked or over-taxed, causing very expensive repairs and maintenance.

The benefits of a robust erosion and sediment control system include:

- All-weather site access
- Improved wet weather working conditions
- Less mud and dust problems
- Reduced stockpile losses
- Reduced clean-up costs
- Better public image
- Fewer public complaints.



1.4 Legal Obligations

Sediment and dissolved or suspended solids are classified alongside pollutants such as lubricants, oils, chemicals and industrial waste as a Prescribed Water Contaminant. It is an offense to place sediment where it could be reasonably expected to wash to surface waters even if not environmental harm has occurred. Fines of up to \$83,500 can be applied.

1.5 Duty to Notify

If environmental harm is observed, there is a legal obligation to notify the State based environmental protection authority. As with any environmental incident, the following process should be followed:

- Complete the Environmental Complaint and Incident Report Form (E-PRO-003).
- Send report to your State Environmental Manager.
- Environmental Manager will advise if the incident is indeed a notifiable incident, at which point the report form should be issued to the Client with the recommendation that the incident be reported to the State Environmental Protection Agency.

Failure to notify the State based environmental protection authority of harm can be an addition to another penalty and may result in a significant fine.

1.6 Offences including “Potential for Environmental Harm”

Each State has their own legal instrument governing environmental offences, which range from on-the-spot fines to environmental protection orders that shut the site down.

Legislation includes the provisions to issue infringements for the “potential to cause environmental harm”. “Potential” refers to situations that, left untreated, would almost certainly be a source of pollution or nuisance, and may have already been (in the absence of evidence).

This is most commonly applied to erosion and sediment control, where either:

- No controls exist
- Controls are not effective
- There is no maintenance or monitoring over controls

Because of this, it is incumbent on the Builder to ensure the environmental controls on their site are effective, and as such, basically wears sole risk for this aspect. Even in rare occasions where ESC Plans are well designed, this is no guarantee that the controls are effective, imposing the need for constant monitoring and education of all site personnel.

Where Civil Contractors take on the Erosion and Sediment Control, it is still Watpac’s responsibility to ensure they are installed and functioning properly.

“Potential for environmental harm” has a very loose definition. Some examples include:

- Not maintaining controls (e.g. sediment fence or shaker grid full of mud)
- Sections of disturbed (unvegetated) earth exposed to external drainage
- Not properly protecting active stormwater inlets
- No overflow allowance
- Not exactly following the ESC plans, or not revising the ESC plans
- Not constructing a sediment basin in exact accordance with design



1.7 Regulation and Enforcement Monitoring

The Australian Department of the Environment are the executors and administrators of all Commonwealth environmental legislation. Commonwealth legislation provides a framework for protection of the Australian environment, including its biodiversity and its natural and culturally significant place. Their main instrument, the EPBC Act, established the use of Environment Protection and Biodiversity Conservation Regulations, which have provided for the issuing of approvals and permits for a range of activities on Commonwealth land and land affecting the Commonwealth. Failure to comply with the Act can result in penalties including remediation of damage, court injunctions, and criminal and civil penalties.

The State Environmental Protection Authorities execute and administrator over their own State level legislation. This legislation is more specific about the limits of emissions of waste and the expectations governing activities such as developments so that such activities can be planned and undertaken with minimal impact to the environment.

State environmental protection authorities include:

- Queensland – Department of Environment and Heritage Protection (DEHP)
- New South Wales - NSW Environment Protection Authority (EPA)
- Victoria – Victoria Environment Protection Authority (EPA)
- South Australia – South Australia Environment Protection Authority (EPA)

State based legislation entrusts enforcement and monitoring powers to the Local Councils, who share a duty to the State Environment Protection Authorities in the responsible management of any developments that are approved within their jurisdictions. This is why Development Approvals will always specify the requirements for Erosion and Sediment Control planning and the limits for discharge into the receiving environment.

Inspections will be undertaken by Local Council members, not necessarily by notification, and often after major storm events (as this is the best time to gauge the effectiveness of environmental controls). In addition, Inspectors from the State Environmental Protection Authority may arrange inspections (usually by notification) if the State or Commonwealth has a stake in the project.

Principals such as the Department of Defence and Airports operate under specific Commonwealth Environmental Law and are exempt from State and Council regulation. Under these circumstances, these entities will have their own environmental managers or compliance officers. They won't issue fines, but they are usually very influential on professional relationships with Clients.

1.8 Strategizing for Compliance with Legislation

The defence to causing discharged sediment is to take all reasonable and practicable measures to minimise the amount of the sediment freed and control the sediment on site. In most cases, that means planning to minimise harm by a suitably qualified professional; implementing site controls as planned; and monitoring the controls to ensure they are effective. It is important to note that even following government published guidelines, drafting a well-designed plan, and establishing the site in conformance with the plan is not necessarily sufficient to avoid penalty. It is important to monitor the controls to ensure they are effective, especially after all storm events, and upgrade the controls if required.

The definition of “reasonable and practicable measures” is open to interpretation. As such, different inspectors will have different opinions and expectations. Likewise, qualified experts in Erosion and Sediment Control can have conflicting opinions over the design and efficacy of controls. Ultimately, it is important to monitor the controls, knowing what the controls are intending to achieve and being able to identify failures.

Under the Stormwater Guidelines published by DEHP (EM368), it is expected that for all erosion prone sites, site specific Stormwater Management plans are developed by an “appropriately qualified person”⁴. This has long been open to interpretation, and in effect has recently come to mean a CPESC (Certified Professional in Erosion and Sediment Control) or—as a minimum—a registered professional Civil Engineer.

1.9 Purpose of this Document

This document is a supplement to the Project Environmental Management Plan. It is not intended to replace a site-specific Erosion and Sediment Control Plan produced by a qualified professional.

It is designed to provide project teams with a greater understanding of why we implement Erosion and Sediment Control and describe the intended function of each control. It also provides a description of how to establish them correctly and monitor their performance.

This document can act as a reference for what the controls should look like and provide further detail where site specific ESC Plans simply call for controls only by name without further detail.

In addition, this document will act as the manual for how Watpac Construction erects erosion and sediment controls. It is intended that enough knowledge will be imparted that users will be able to detect under-designed engineered ESC plans and supplement them as necessary.

Unless noted as being “use only when specified” in each section, the controls contained herein will be the default minimum requirements, when and where applicable, as judged by the Environmental Managers and/or Project Teams.

2 Water Discharge Quality

2.1 Discharge Limits

The water quality objectives are set in each State by various policies. In Queensland, State Planning Policy (SPP) sets the construction site minimum as 50mg/L TSS. DA conditions or other permits may enhance these conditions based on ANZECC or some other guidelines.

Although objectives can vary by State and Local Council, and sometimes even by DA, the limits only deviate in small measure. The limits provided below are consistent with most published guidelines, a predominantly the Department of the Environment “Australian and New Zealand guidelines for fresh and marine water quality: Volume 1”:

Table 1 Discharge Limits Information

Pollutant	Discharge Limit
Turbidity	No more than 50mg/L TSS (or 75 NTU)*, or less than 10% over upstream water
pH	pH 6.5- 8.5
Coarse Sediment	None
Hydrocarbons and other chemicals	None

* The commonly accepted relationship 50mg/L TSS = 75 NTU, but lab tests should be used to confirm your site correlations as this can vary depending on soil characteristics.

2.2 Coarse Sediment

Coarse sediment is any sediment over 3µm in diameter. “Silt” and “sand” in the adjacent image is considered coarse sediment.

The limits provided mean that no coarse sediment is allowed to escape from the site. It is easy to visually identify non-compliant control of coarse sediment.

2.3 Fine Sediment (Total Suspended Solids)

Total suspended solids is a water quality measurement usually abbreviated TSS, and refers to the dry-weight of particles trapped by a filter, typically of a specified pore size. TSS of a water sample is determined by pouring a carefully measured volume of water (typically one litre; but less if the particulate density is high, or as much as two or three litres for very clean water) through a pre-weighed filter of a specified pore size, then weighing the filter again after drying to remove all water. As such, TSS can only be properly measured in a laboratory.

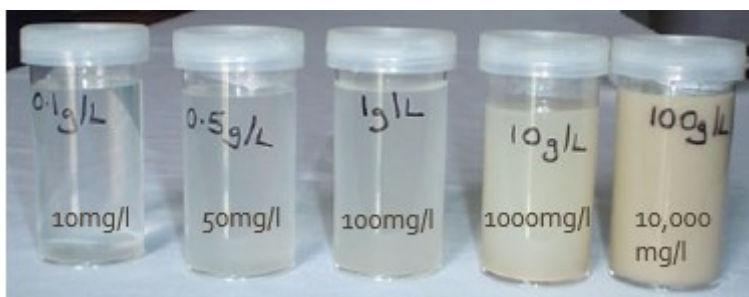

Examples of TSS values

2.4 Turbidity

Turbidity is the cloudiness or haziness of a fluid caused by individual particles (total suspended or dissolved solids). Is it measured in Nephelometric Turbidity Units (NTU). Water meters will cast a light and measure how much that light is diffused by suspended particles. In this way, turbidity can be measured on site with water meter. There is a strong correlation between turbidity and TSS, so it can be assumed that by complying with TSS, we are also complying with fine sediment.

The commonly accepted relationship 50mg/L TSS = 75 NTU, but lab tests should be used to confirm your site correlations as this can vary depending on soil characteristics.



50 NTU

2.5 Acidity or Alkalinity (pH)

pH is a measurement of how acidic or basic something is. It is measured on a scale from 0-14. Acidic values are from 0-7, with 0 being the most acidic. Basic numbers are from 7-14. A neutral pH is 7 (an example of this would be distilled water). The pH scale, like the Decibel Scale and the Richter scale, is logarithmic, meaning that each unit change (e.g., 5 to 6) is a tenfold change in the pH of the substance. Water with a pH of 5 is 10 times more acidic than water with a pH of 6.



Graphic indicating the hostility of pH levels

When treating pH, hydrated lime raises pH (if too acidic/low), and hydrochloric acid lowers pH (if too alkaline/high).

3 Erosion and Sediment Control (ESC) Planning

3.1 Calculating Erosion Risk

Erosion and Sediment Control (ESC) Planning has an order in which controls must be implemented. Following the International Erosion Control Association (IECA) Best Practice Guidelines, the required controls are proportionate to the risk provided from calculating the Revised Universal Soil Loss Equation (RUSLE) value. This value takes into consideration location variables including size of the site, rainfall erosivity, soil erodibility, topography, cover, soil loss rates, etc. This calculation is best left to a CPESC (Certified Professional in Erosion and Sediment Control).

Alternatively, Geotechnical Reports will often state the Emerson Class. An Emerson Class of 1 to 3 suggests the soil has a high erosion risk and requires close monitoring and careful planning.

3.2 Priority of Controls

The order of priority in which controls are designed and implemented is:

- Divert clean water around the site;
- Direct dirty water to sediment controls; and
- Minimise erosion on site through cover and controlled flows.

Clean water diversions or permanent stormwater infrastructure should be one of the first steps on a construction site. Guidelines now stipulate that turbid water on site must be treated, so preventing clean water from entering the site reduces the burden on the sediment controls.

Sediment controls are the most critically important step in ESC. As soon as water enters the site, it becomes Watpac's responsibility, and must be discharged lawfully.

Erosion minimisation is important to further reduce the burden on the sediment controls. This includes measures such as lining swale drains, using rock check dams, covering stockpiles with tarp or seed-binder, scour protection, etc. Erosion controls are considered reasonable and practicable measures.

3.3 Types of Controls

Depending on the RUSLE value, various “Types” of sediment traps are specified under the IECA guidelines. They are ranked based on their ability to trap a specified grain size. In all circumstances, Type 3 Controls are required—this is the minimum standard. For most site circumstances on Watpac projects, type 2 controls are required, as they are intermediate level—above what might be expected of smaller construction sites. Most recent projects will require Type 1 controls— advanced levels of controls.

Type 3 Controls



Type 2 Controls

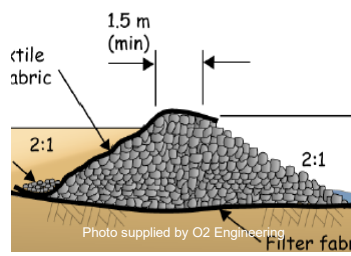

Type 1 Controls

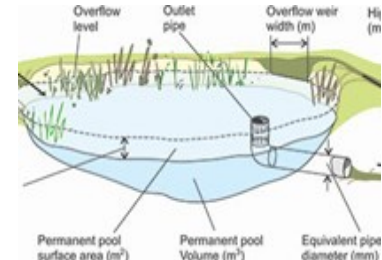

4 Sediment Fencing

4.1 Description

Sediment fencing, aka Silt Fence, is a Type 3 control. A typical fence consists of a piece of synthetic filter fabric (also called a geotextile) stretched between a series of wooden or metal fence stakes along a horizontal contour level.

Sediment fences are essentially a porous dam that ponds up-slope water, allowing coarse sediment to settle at the bottom. It does not work as a filtration device.

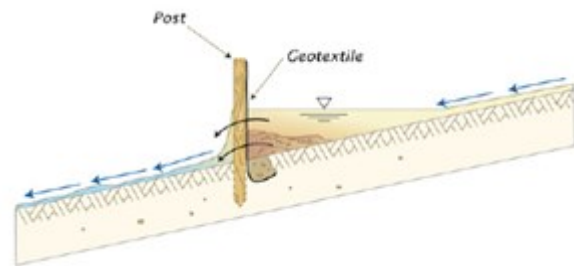

Picture supplied by O2 Engineering

4.2 Establishment

1. Mark out the setout of the sediment fence and dig a 200mm trench along this line on the side receiving run-off (i.e. within the site boundary).

2. Hammer the fence stakes or posts into the trench, ensuring they are secure. The supporting pegs can be hardwood timber or steel pickets, which stick out from the ground by about 600mm. Pegs should only be visible from the outside of the site.
3. Attach silt fence fabric to the supporting pegs by either a stapler, tie wire or zip ties. Make sure the fabric is secure and doesn't move on the peg as over time these pegs will be under immense strain from the captured sediment and water.
4. Backfill the trench with the excess spoil created with the trenching process, making sure that the fabric is in a "j" position under the ground.
5. Pack the soil down into the trench, especially around the pegs as these are the structural points of the fence.

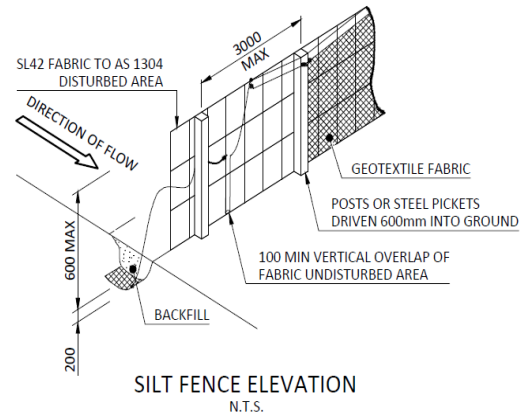

Where positioned near steep gradients, fences should be 1m from the end of the batter, otherwise two fences will be needed.

Unless otherwise noted, the fabric material for the sediment fence should be polypropylene, polymide, nylon, polyester, or polyethylene woven or composite (non-woven) fabric, at least 7000mm in width and a minimum unit weigh of 140GSM—Bidim A34 or equivalent. All fabrics should contain ultraviolet inhibitors and stabilisers.

Key components to remember:

- Aim to maximise ponding.
- Return back up-slope to prevent flow around fence.
- Ensure bottom of fence is well anchored.
- Maintain regularly.
- Install as close to source as possible.

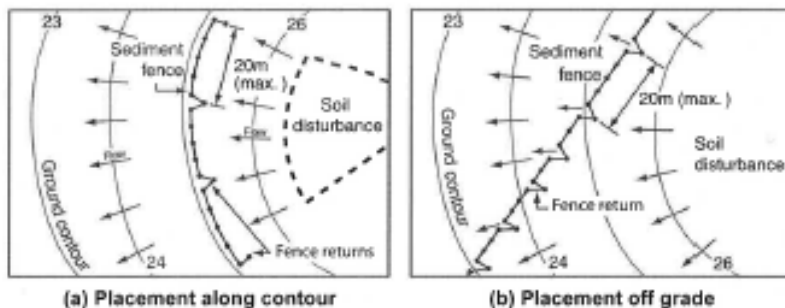

Occasionally, Filter Fence may be specified. The main difference is that the geofabric used in filter fence non-woven. Sediment fence is woven.

The result is that sediment fence creates more ponding, while filter fence allows steadier flow. Both will stop the coarse sand particles releasing, but the filter fence will also get some of the medium sized (silt) particles. Neither will reduce the turbidity in the water released.

This product is rarely specified and should only be used where explicitly called for. Otherwise it should be anticipated that the standard sediment fence is intended.



4.3 Monitoring

Sediment fences should be monitored for build-up of sediment, particularly after each storm event. Build-up of mud can be buried or spread back around the site.

Keep an eye out for breakages along the fence, or anywhere the turn-down has been dug up.

Monitor the fence for erosion. If there is erosion occurring, it may be because the sediment fence is directing all run-off to a particular point. Zig-zagging the fence at an angle to the flow will spread the load. Otherwise, install returns.

5 Stockpiling

5.1 Description

In the context of Erosion and Sediment Control, Stockpiling is a pile or storage location for soil, sand, mulch, or any dispersible particulate material.

Stockpiling requires planning of location and protection method. Material that is intended to be stockpiled for longer than 10 days requires protection—as a minimum, this should be a sediment fence enclosure.

It is unnecessary to enclose gravel or clay stockpiles in sediment fence, particularly if the stockpile is on a surface that prevents travel (such as clay). If stockpile is to remain for some time (10 days or more), it is suggested that a sediment fence is installed. The critical consideration is ensuring runoff from the stockpile is captured and directed to sediment controls downslope.

If stockpiles are due to remain for significant periods (25 days or more) will require weather protection, such as below.



In the above example, we can see jute mesh sheets overlaid over a stockpile and pinned in place with stakes. The whole stockpile is bundled by sediment fence. This is exemplary control but should only be necessary if warranted, i.e. if the stockpile is to have residence for a long time, the soil is highly dispersive, or the soil absolutely must be contained (for example it's contaminated).



This project hydromulched their large stockpile. This is a very effective treatment for large stockpiles with a long residence.

5.2 Establishment

- Stockpiles should be planned to be outside of overland flow paths as much as possible.
- Ideally, stockpiles should not exceed 2m. If this unavoidable, extra care must be taken in their protection (see items 3 and 4).
- If the stockpile is to remain for 25 days or more, dispersive or clayey material should be completely surrounded by a sediment fence, to capture loosed sediment downslope and divert water around them upslope. Fences should be spaced 1.0m away from the foot of the stockpile to avoid overloading the sediment fence.
- If the stockpile is dispersive or clayey materials due to remain for 25 days or more, or otherwise has the potential to cause environmental harm, weather protection will be required. Weather protection can either be:
 - » Geotextile fabric
 - » Tarp
 - » Jute mesh or coir mesh
 - » Mulch
 - » Biodegradable polymers (e.g. "Gluon" Rainstorm.com, "Stonewall" Vital industries.com)
 - » Grass cover (aka seed retention or seed binder, sterile and fast growing, such millet which dies off after 6 months. e.g. "Hydroguard" Perfect Earth, Petro-tac" for sloping black cracking clays)
 - » Hydromulching
- Topsoil stockpiles in excess of 1.5m can be harmful to the organic qualities of the topsoil. Similarly, topsoil that needs weather protection requires a breathable membrane such as jute mesh or coir mesh.

5.3 Monitoring

Stockpiled should be monitored for the leakage of sediment after rain events, and dispersion during windy conditions. Ensure they are located correctly and adequately protected.



6 Up-Slope Water Diversions

6.1 Description

Up-slope diversions are referred to as diversion channels, bunds, berms, banks, batters, or water bars. They are implemented for projects downslope of overland flow (i.e. not surrounded by flat terrain) and are only needed when specified. They are basically humps outside the site that divert as much run-off and water as possible, thereby reducing the possibility of erosion occurring within the site.

Ideally, flows will be intercepted at the site boundary and diverted around the perimeter of site in a 'clean water drain' which discharges into the watercourse at the downstream boundary. This drain should wrap around the site and prevent any external flows coming onsite.

Diversion channels can be constructed from various methods, including compacted earth, silt socks, coir, mulch, concrete etc. They are often designed with an adjacent swale drain (see section "Drainage Channels") to direct the diversion to the appropriate controls.

Straw bales can only be used as flow diversion or check dams but may require regular maintenance. Straw bales offer no filtration and should not be used as sediment traps to protect stormwater inlets. Straw bales should be tightly compacted staked in to prevent movement.



6.2 Establishment

1. Installation will depend on the material chosen/designed. Compacted earth can just be hand compacted. Logs or other laid diversions should be dug-in slightly.
2. Ultimately the intent is to create a continuous cohesive barrier that channels water wholly downstream. Fractures or inconsistencies can lead to erosion.
3. Diversion channels are often considerably more effective with a corresponding swale drain. This will ideally involve lining with swale drain. Refer to the section on swale drains for more information.
4. Ensure run-off is clean.

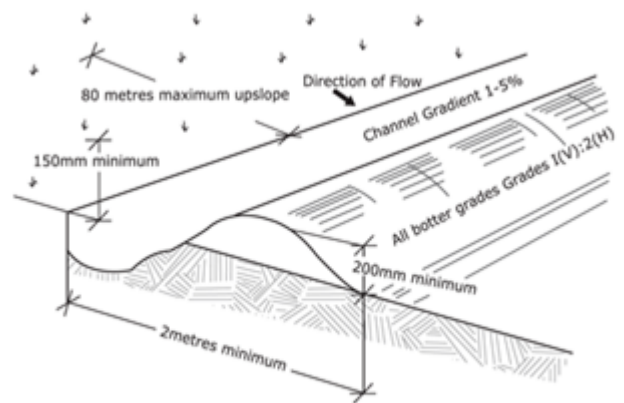

Note: Only to be used as temporary bank where maximum upslope length is 80metres

6.3 Monitoring

Diversion channels should be checked to ensure they aren't breaking down or being eroded, and that the run-off they are diverting is not causing further erosion down the line. Run-off should be at acceptable discharge limits for escaping.

7 Drainage Channels

7.1 Description

Drainage channels are referred to as swales, catch drains, table drains, or inverts. They are drains that catch water and channel them to a controlled drainage point. They are only needed when specified.

End point controls can be varied depending on the Type of sediment trap required by IECA guidelines. End points can include:

- Sediment Basins
- Sediment traps
- Rock-bed scour protection
- Turf buffer zones
- Level spreaders into turf



Drainage channels require some form of erosion protection; that can either be linings or check dams. When the soil is dispersible and the gradients are steep enough, both are required;. If a drain is to be cut into dispersive soils, then the drain must be lined with non-dispersive soil to a minimum of 100mm thick before lining.

Linings can be turf (example in picture above), geofabric, plastic sheeting, coir mesh, and jute mesh. It is important that the lining edges are keyed and overlapped in the direction of flow to prevent undermining. Plastic sheeting requires that the velocity be tempered, particularly the exit velocity. Alternatively, concrete or bitumen can be used.

As an alternative to lining, Check Dams can be used where drains are less than 10% in gradient. They are used to prevent scour by reducing flow velocity. They can be made of rock (example seen above), sandbags or triangular grid sediment fence. As a rule of thumb, they should be spaced such that the top of a lower dam is level with the bottom of the higher dam.

council usually refer to their own roadside drainage as table drains.

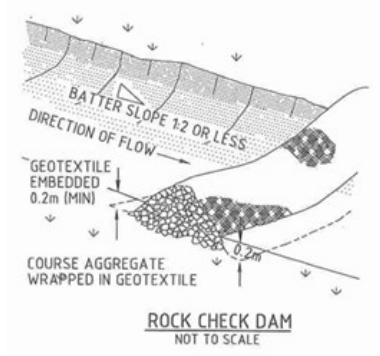
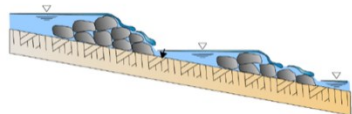

7.2 Establishment

- Drains can be cut in via shovel or plant, as long as they're to the dimensions specified in the project ESC Plans.
- Dispersive soils require a 100mm bed of non-dispersive soils before lining.
- Procure erosion control measures (described above):
 - » Lining should be laid hard against the ground, lapping each sheet in the direction of flow.
 - » Check Dams should be spaced as per the ESC plans.

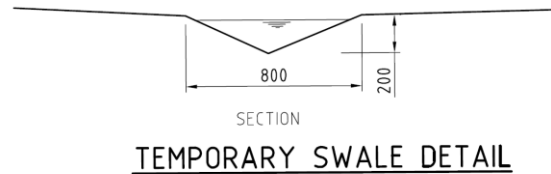

The most important thing to remember is that drainage channels should be stabilised, so that flowing water doesn't erode and disperse soil. Below is an example of a drain constructed of geofabric base with velocity-dampening check dams, with a sediment fence weir system at the exit.





7.3 Chutes at Outflow

Drainage Channels should be directed into chutes or outlets. Anywhere run-off needs to take a steep drop, e.g. into a sediment basin or an overflow leaving the site, should be treated as a chute. All chutes should be specified and designed by a qualified professional.

Rock chutes are acceptable into sediment basins, sediment traps, turf zones, or elsewhere where another form of sediment control exists. The linings described in “Drainage Channels - Swales” may also be used.

Turf is the best filtration device so should be used where the chute is the final overflow point of the site.

The outlet of chute, culvert, or any other channel with a concentrated flow, must be stabilised to protect the receiving surface, aka scour protection. A stabilised rock pad is often best. This can convert the concentrated flow to sheet flow which allows dispersal into turf.

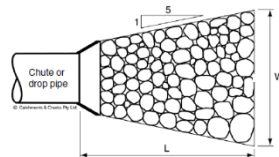

Rock Chute

1. Rock should be recessed into the channel or chute, and lower than the adjacent surface.
2. Lining should fully cover the chute and be adequately wide.

Turf Chute

1. Turf should be laid in a stretcher-bond pattern across the chute, not down the chute.
2. Lining should fully cover the chute and be adequately wide.

Outlet

1. Scour Protection
2. Bedded and grouted in, or with a geofabric base

7.4 Monitoring

Make sure no erosion is being caused on either side of the chute. Ensure that the end of the chute is adequately stabilised against erosion.

Periodically check to ensure the linings aren't being eroded underneath or causing erosion along the sides. Ensure the drains are effectively carrying water at a velocity that doesn't cause erosion. Ensure the exit points are free of erosion.

8 Sumps and Sediment Traps

8.1 Description

A sediment trap is a general description for the last point in which run-off is collected and allowed to settle before passing through. They work by trapping coarse sediment and, as with sediment fences, do not filter. They are typically installed at the perimeter of a site or above storm drain inlets, to allow sediment to settle before letting run-off escape into the drainage system.

A sediment trap can also be used like a check dam for concentrated flows, around roads and in swale drains.

Sediment traps can be constructed in multiple ways, depending on their application. Sediment Traps will only be required as detailed on the ESC plans. All sediment traps are Type 2 Controls.

Sumps, Perimeter Sediment Traps, High-Efficiency Basins

Used where Sediment Basins can't be installed due to size. They are a Type 2 Control. They work by letting water pond and settle for overflowing or being serviced. The in-flow chute should be scour protected. They must have a lined/stabilised overflow to allow high flow bypass into turf or other discharge point.

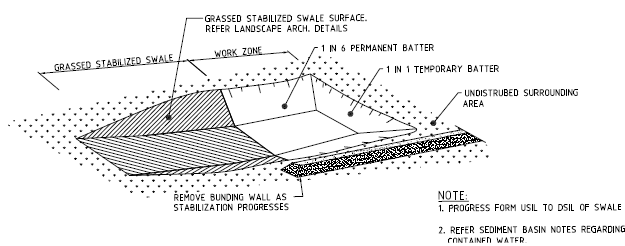

Rock Filter Dams

Rock Filter Dams use rock to cause the ponding effect required to settle sediment from water. They are a type 2 Control. It is constructed by forming a bank of rock and lining the face with geotextile. They should only be used under the design of a qualified professional.

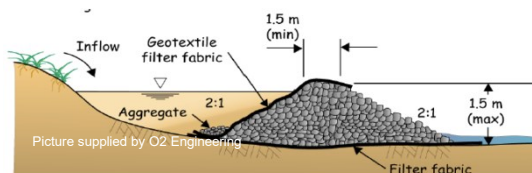

Kerb Inlet Sediment Trap

See section: “Protection of Stormwater Infrastructure”. Protections around stormwater inlets can also be known as a sediment trap and selection of the trap depends on the type of inlet.

Field Inlet Sediment Trap

Field inlet sediment traps are used to protect connected stormwater field inlets. They are a Type 2 Control. Ideally the gravel should be recessed into the ground slightly. They won’t achieve the required discharge limits on their own but are an excellent measure to discharge to a sediment basin, sediment trap, or turf buffer zone.

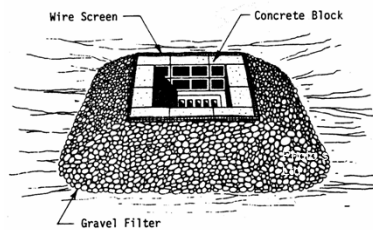

Concentrated Flow Sediment Trap

Concentrated Flow Sediment Traps are essentially the same as check dams, except they aren’t necessarily in a drain—they should be located wherever a concentrated flow path is detected, but the flow should continue uninterrupted. In that sense they are sometimes a reactionary measure where concentrated flows are detected by site investigations. A common application is on the shoulders of roads

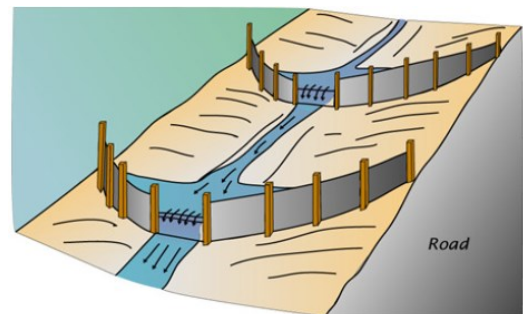

Concentrated Flow Sediment Traps are U-shaped with a spillway/weir in the centre to allow settled run-off to crest over it.



8.2 Monitoring

All Sediment Traps should be monitored to ensure that their overflow is not causing erosion.

Perimeter Sediment Traps, when used in lieu of Sediment Basins, should be treated as a Sediment Basin (see section: “Sediment Basin”).

They should be monitored during storm events to ensure they are working, and after storm events to check if they need cleaning out.

9 Sediment Basins

9.1 Description

Sediment Basins are one of the most effective Erosion and Sediment Controls, the other being dense turf, and are a Type 1 control. They function by letting water pond and allowing sediment to settle at the bottom. They must have an emergency spillway to allow high flow bypass. Sediment basins are design to match the area and soil type of catchment, as well as the local rainfall. The volume required for sediment settlement is directly proportional to the rate of spill loss determined by the RUSLE equation.

As a general rule, sites of 1 hectare or more will require a sediment basin.

Sediment Basins must be carefully designed by a qualified professional, as State Environmental Protection Authorities view them as significant infrastructure. Once designed, they must be constructed exactly in accordance with design, and a Surveyor should confirm and map the dimensions on a plan.

To achieve the discharge limits, Sediment Basins usually require chemical treatment. This can be undertaken manually after a rainfall event. Ideally the water should be tested with a water meter first, and the data read against the discharge limits described in section 2.

After treatment and testing, water can be pumped out. Untreated water can be vacuumed up and treated as contaminated waste.

Retention Basins, Detention Basins, or Bio-Retention Basins are considered different in that they are permanent fixtures based on the final state of the environment after construction is complete.

Decommissioning basins involves vegetative stabilisation of disturbed areas. Ensure the soil below is not saturated. Ensure ESC redundancies are built in during the decommissioning process.

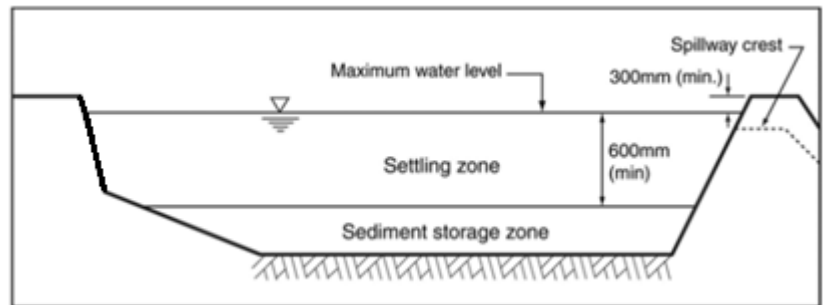

9.2 Establishment (Type D)

- Ensure detailed design drawings are on hand and worked to during the construction of the basin.
- Stabilise the bottom with hard rock or gypsum. Over excavate basin 200-300mm then cap with material. Gypsum can be worked through and compacted (500kg per 100m³).
- The overflow spillway must be to the specified dimensions and included evenly graded rock underlain with geofabric.
- The in-flow chute requires energy dissipation. In-flow can either be lined or a temporary culvert.
- Ensure a height-stick is erected to monitor sediment storage zone and height of collected water.
- Arrange survey and complete a “Certification of Basin Construction”.

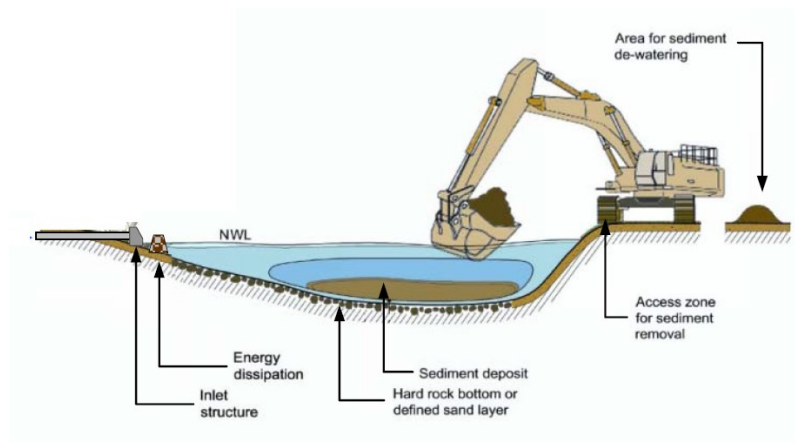

Sediment Basins require sizing by an Engineer or Certified Professional in Erosion and Sediment Control (CPESC). Ideally, the dimensions will be provided as an indicative volume to allow for adaptable width, length and depth to fit site constraints.

The drainage point from the basin must be drawing from as close to the top of the basin as possible. This may be having the pump hose on a float, or with a drainage riser (examples of passive drainage and pump attachment shown below).

Water in basins can be collected and use as dust suppressant, eliminating the need for treatment.

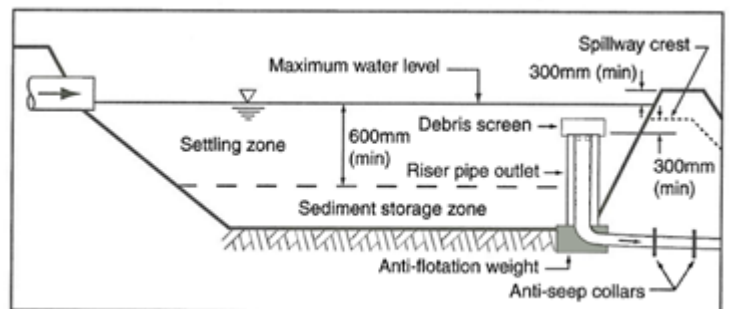

The height stick should be marked out with the designed heights of the sediment storage zone, settling zone, and the maximum water level (300mm below spillway). The levels should follow the engineered plans for the basin. It is recommended that bright paints are used to aid in the visual assessment.

When there is water above the basin sediment storage zone, initiate the process of servicing and emptying the basin.



This example above shows the sediment basin being treated with Turbicleer before being pumped into a stabilised drainage channel and leaving the site.

9.3 High Efficiency Sediment Basins (aka Auto-Dosing, Type A/B)

Continuous flow basins (Type A) represent a big step change in what is considered best practice sediment control. 'Traditional' basins (Type D) are limited in their ability to capture fine sediment (and the nutrients, heavy metals and pesticides which may be attached to these clay particles). The establishment can be more expensive as it requires an automated chemical dosing system (which includes regular top-up), and the site has to drain to the basin's single point of entry. They are considered the most effective sediment trap for clayey soils.

In Queensland, from July 2017, all operational works approvals will have the requirement that exposed areas greater than 2500m² must be "provided with sediment controls which are designed to achieve at least 80% of the average runoff volume of the contributing catchment treated (i.e. 80% hydrological effectiveness) to 50mg/L TSS or less, and pH in the range of 6.5 to 8.5". Put another way, our site controls must treat 80% of the rainfall runoff that enters the site, to achieve those water quality objectives.

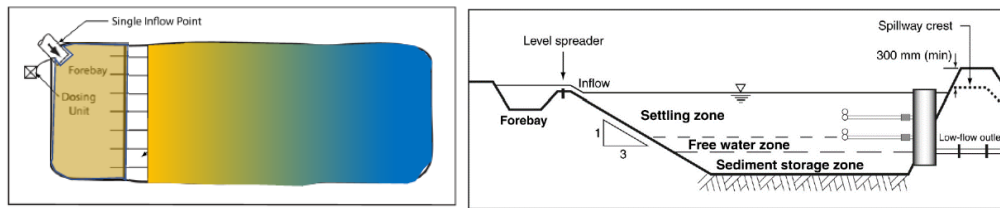

Type A Basins should also be supported by a skimmer system for drainage, effectively slowly filtering and drainage from the surface, as depicted below.





Examples of auto-dosing systems on BESIX Watpac sites



9.4 Monitoring and Servicing

Monitoring of sediment basins should be undertaken by trained professionals.

It is basically a process of monitoring the height stick—if there is water above the basin sediment storage zone, initiate the process of testing and treating the water.

The sediment settling/storage zones will require clearing. Excavated sediment can be buried, spread back around the site or disposed. Sediment should be allowed to dry before dispersal.

Basins should be monitored during storm events to ensure they are working, and after storm events to check if they need cleaning out.

Ensure records are kept of each inspection. Refer to the flowchart on the next page—text highlighted in blue are the minimum required records to be captured on each inspection report.

It is recommended that the Watpac form “E-FRM-005 Water Meter Report Card” be used to monitor the sediment basin. As a minimum, monitoring should be done weekly, as well as during construction, after every storm event, and as required to ensure there is no spillway overflow.

9.5 Reducing Turbidity for Discharge

To achieve discharge water quality objectives, sediment can be settled naturally or with the use of a clarifying agent (coagulants and flocculants).

- **Coagulants.** Commonly used coagulants are gypsum and aluminium, and work via ionisation. Sediment particles are uniformly negatively charged, so they repel each other. Coagulants neutralise this charge, allowing cations (positively charged particles) to agglomerate to the sediment particles, weighting these newly formed ionic compounds enough to sink.
- **Flocculants.** Many flocculants are multivalent (combining power measured by the number of available atoms) cations (positively charged particles). Flocculants are generally a long-chain polymer, such as biopolymer or polyacrylamide. They work similarly to the ionisation processes described above but are augmented by a bridging interaction involving polyelectrolyte chains that allow fast adsorption and settlement. Flocculants can be extremely effective and fast acting, but are strongly affected by several parameters, including mixing speeds, mixing intensity, and mixing time.

Some experimentation with the targeted soil may be required to find the optimal clarifying agent. A popular and reliable product is Aluminium Chlorohydrate (ACH), which has a low eco-toxicity.

A “jar test” should be done to discover the best product to use on your site’s soil.



A visual example of the effect of clarifying agents in a jar test.

Alternatively, water in basins can be collected and use as dust suppressant, eliminating the need for treatment.

Another successful method has been to dump stockpiled spoil into the basin, which will then soak up the water. This can be used where stockpiled spoil is available and was due for disposal anyway, and the water isn't too deep. The soaked material can be scooped out and baked in the sun to remove moisture.



The effects of an effective flocculant on extremely turbid water.

9.6 Reducing pH for Discharge

If the pH of water is outside the range 6.5-8.5, it needs to be neutralised. Hydrated lime raises pH (if too acidic/low), hydrochloric acid lowers pH (if too alkaline/high).

9.7 Protocol for Discharging

Discharge can be tested in the following ways:

- **Water probe.** Refer to section 17 of this plan for guidance on using a Water Quality Probe. The advantage of this instrument is that it provides field readings for immediate use, on multiple metrics including turbidity in NTU, temperature, pH, dissolved oxygen, salinity and more. The turbidity readings of these instruments are generally not to be considered 100% accurate, so it's important to do initial laboratory tests for Total Suspended Solids (TSS) to ensure the correlation is close enough to rely on the water probe.
- **Laboratory Reports.** This is the most reliable way of determining water quality. It is recommended that a few samples of lab tests are done for Total Suspended Solids (TSS) to establish a correlation between TSS and the field readings for NTU using the water probe.
- **Turbidity tubes.** These instruments can be ordered online and at the time of writing are indicatively priced at around \$70 each. They work by filling the tube full of water, and slowly tipping water out until you can read the markings at the bottom of the tube by looking down it.



When you can clearly see the bottom marking, look on the side of the tube, and will give you the indicative turbidity. It may sound unscientific, but it provides a reading within 10% of any mobile testing instrument—enough to be relied upon for discharge.

- **Bottle to light.** Capture a bottle of water to the light—you may easily be able to spot particulates. This is another unscientific way of determining the water quality but can be used in a pinch.
- **Submerging Hand:** If you lose clear visibility 10cm deep into the water, that is a good indication the water is too turbid to discharge. This is obviously an unscientific way of determining the water quality, but Inspectors will often rely on this in absence of proper equipment.

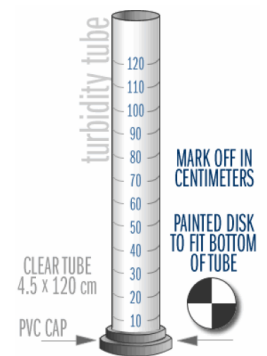

Before discharging anything into external drainage, appropriate tests must be conducted. Ideally, these tests should be one of the first four methods of testing provided above, as some records should exist prior to discharge. This can be recorded on E-FRM-005.

When pumping out, remember to pump from the top of the basin, and pump only until it hits the settlement zone, stopping before it gets to suspended solids, which usually occurs at about 300-600mm from the bottom (even after flocculation and settlement).

9.8 Decommissioning

Following completion of the works and stabilisation of disturbed areas, basins should be removed, or integrated into permanent stormwater systems.

Temporary sediment controls must be installed downslope during decommissioning. Captured run-off must be properly disposed of prior to removal of the basin.

Following removal, the footprint of the disturbance must be quickly stabilise.

10 Vehicle Entry and Exit Grids

10.1 Description

Vehicle entry/exits (aka entry pad) are the designated point of entry for all plant and vehicle traffic. It is designed to provide a terrain that causes the any sediment stuck to the vehicles to be dislodged by vibration and friction against uneven surfaces.

They are composed of two elements:

- Shaker grid (aka vibration grid, cattle grid, rumble pad)
- Rock pad (aka dumped rock, rumble rock, riff-raff)

It is imperative with vehicle entries that trapped sediment and overland flow is forced to remain within the site boundary. This can be managed via berms or grading the entry to a fall.

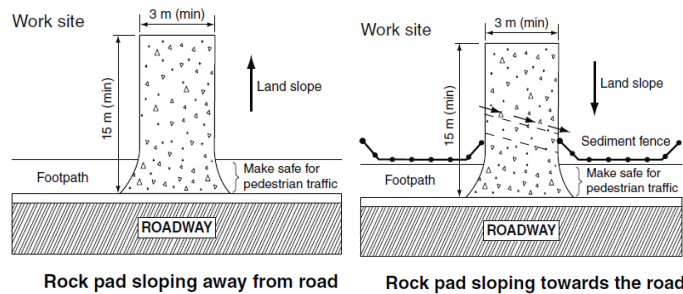

They should ideally be a 15m stretch of rock, or otherwise as long as possible, with the shaker grid in the middle. The rocks should extend all the way to the sealed road surface. Rock selection is critical to maximise voids.

Washdown bays will be required for extremely clayey and muddy terrain, or if the site is either contaminated, contains a high population of known weeds, or is a fire ant restricted zone.

When required, wash bays for our purposes are usually manual, involving high pressure hoses and inspection before leaving. High pressure hoses will be required in event of fire ants and contamination. Inspection and washdown bays with hoses must be installed with a drain into a sump lined with plastic. Backwash must be tested for contaminants (including oils, detergents, ants etc). If contaminated, it can be disposed of by a licensed liquid waste contractor. If it is clear of contaminants, it can be drained to turf, or drained to stormwater if water is tested for turbidity.

Another option that has been experimented with is rolling out layers of geofabric along the entry, exit and haul roads.



Disconnected heavy-duty plastic shaker mats are also available and have been highly effective.

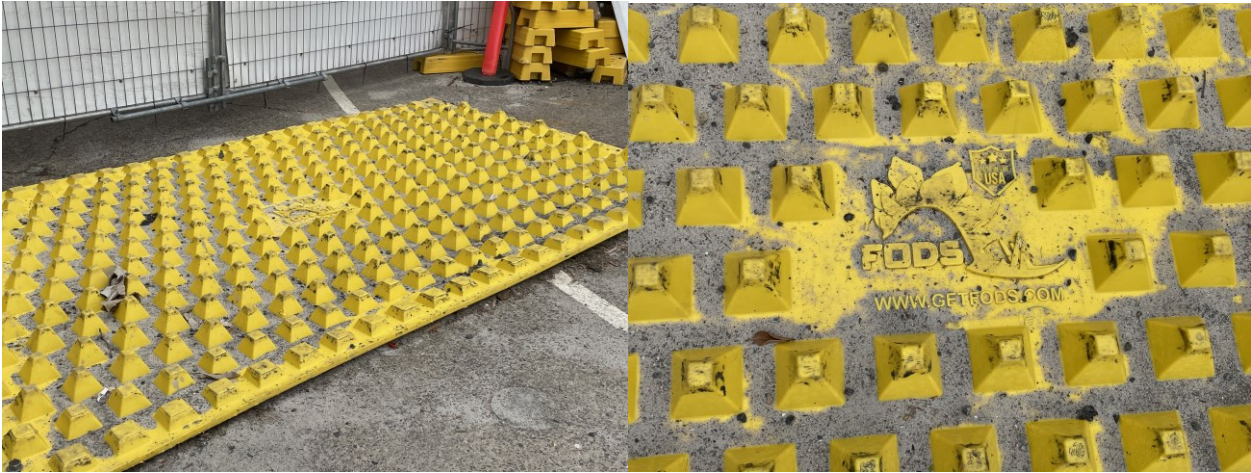

10.2 Establishment

Entry Grid

1. Set out extent of vehicle grid. Ensure rock pad is carried all the way to the sealed road surface.
2. Dig out recess for the shaker grid.
3. Lay geotextile filter cloth beneath rock pad position.
4. Lay rocks, ensuring there is some embedment into the ground.
5. Ensure sediment traps/controls are in place to capture run-off and backwash if the entry slopes toward the road.

Manual Washdown Bay

1. Cut a small recess into the ground (for example, 5m X 10m x 0.3m deep) and establish a bund around all sides—this will be the washbay.
2. Cut a nearby sump (for example, 1m X 1m X 1.5m deep, depending on your water volume), and cut out a channel leading from the washbay into the sump.
3. Line the washbay with plastic and cover with rock (150mm diameter) to a depth of around 300mm.
4. Place a shaker grid over the washbay with an entry and exit ramp (either dumped rock or a berm).
5. Line the sump and associated channel with plastic.
6. Establish a high-pressure machine to wash the wheels as they drive over the washbay.
7. Erect signage informing all drivers to pull up and inspect the vehicle and wash if required, noting to inspect the sides, under the vehicle, and in nooks for compacted up sediment.
8. Contaminated water ran to the sump and can be sucked out and taken to an approved dump site by a licensed liquid waste contractor. If the water is not contaminated, it can be reused as dust suppressant.

10.3 Monitoring

Clear out shaker grid and rock pad when sediment has built up. Ensure no runoff or backwash is escaping out of the site, particular where the entry slopes toward the road.

Check the external road surfaces for sediment trails leaving the site. If sediment trails are visible, arrange a street sweeper. Alternatively, when possible, the sediment can be broomed back into the site. Sediment should *not* be hosed down.



If a manual wash-bay is installed, periodically check the sump for water levels—when full, arrange vacuum disposal by a licenced liquid waste contractor.

11 Concrete Washouts

11.1 Description

After concrete is poured on site, the chutes of ready mixed concrete trucks and hoppers of concrete pump trucks must be washed out to remove the remaining concrete before it hardens. Equipment such as hand tools also need to be washed down. As off-site wash out can be expensive, some project will choose to have an on-site concrete washout. This can come in various forms.

Concrete washwater is caustic and corrosive, having a pH of near 12. Its high pH can increase the toxicity of other substances in the surface waters and soils. Caustic washwater can harm fish gill and eyes and interfere with reproduction. Rainwater polluted with concrete washwater can percolate down through the soil and alter the soil chemistry, inhibit plant growth, and contaminate the groundwater.

11.2 Establishment

Excavated Concrete Washout Pit



A hole should be dug out roughly as long and wide as a concrete truck, with a depth to service the washout loads provided by the site (usually about 1.2m deep).

The pit should be lined with plastic that is weighed or dug-down to prevent movement.

Safety barriers and signage should indicate the method of approach and clearly signal to the site the area to wash out.

Washwater can be left to evaporate or collected and treated as contaminated waste.

Bin wash-out

Similar to the above, some teams may choose to wash out into the skips, where concrete can also be blown out. The skips must be lined with plastic. This must also be discussed with your waste contractor.



Kibble Tray

Kibble trays can be rented or bought that act like washout pits, but do not require excavation or lining and are designed not to leak.



Settlement Tanks

In situations such as the CBD where there is no room for washout space, 3 layer sediment tanks can be deployed which allow washwater contaminants to settle before overflowing into the next tank. This water will be highly alkaline.



Concrete Pump Washout Bags

In situations where the pump may need to be on street, or in a space that may escape easily, Concrete Pump Washout Bags can be used. These go for \$35 each in bales of 10. This collects backwash, and after it dries, can be disposed of into general waste or used for recycling (as it will be pure concrete).



Off-site Washout

The concrete supplier can washout out back at their facilities. This usually carries a surcharge but is an environmentally safe option. In extremely space restricted situations, this may be the only option.

11.3 Monitoring

Concrete washout facilities should be inspected daily and after heavy rains to check for leaks, identify any plastic linings and bunding that has been damaged by construction activities, and determine whether they have been filled to over 75% capacity. When the washout container is filled to over 75% of its capacity, the washwater should be vacuumed off or allowed to evaporate to avoid overflows. Then when the remaining cementitious solids have hardened, they should be removed and recycled. Damages to the container should be repaired promptly. Before heavy rains, the washout container's liquid level should be lowered or the container should be covered to avoid an overflow during the rain storm.



Situations like this, where slurry or backwash can wash away or seep into landscaped ground, are not acceptable.

12 Wet Trade Backwash

12.1 Paint and Plaster Washouts

Paint and plaster washouts are used to wash down the tools of painters and plasterers. The backwash of these trades can be highly toxic and alkaline (due to the cement in plaster), which does not meet the water quality discharge objectives.

As such, paint and/or plaster washouts are established on site which allow treatment or collection rather than washing out directly into stormwater.

Tool Cleaning Process

At the end of the day, wipe or squeeze excess paint onto an absorbent material such as old rags, shredded newspapers or cardboard boxes. When dry and can be thrown into general waste.

Wash brushes, rollers and other equipment with water in a large container. These can be hooked into temp sewerage directly, or via a stack riser. Alternatively, they can be collected at the bottom of buildings in large IBCs (plastic drums) for settlement prior to discharge.

Dulux Envirosolutions—Envirowash products are available at Dulux stores, and should be expected that Painters will be using these products to settle out the paint suspended in the water. Once settled and clean, this water can then be discharged to sewer. The paint sludge at the bottom should be periodically cleaned out, dried, and disposed of in general waste.

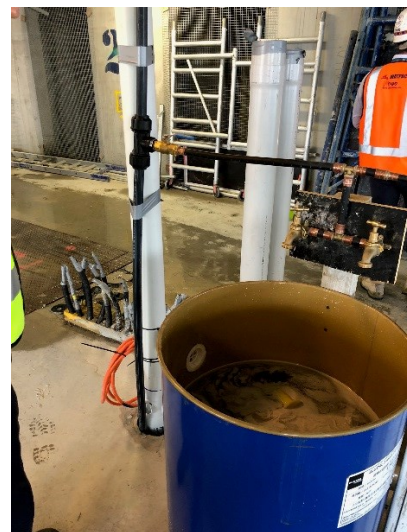

Discharge

City projects and those that need to discharge treated water into existing sewer infrastructure will require a trade waste approval. Applications can be made to sewer infrastructure managers such as Queensland Urban Utilities for a “Special Approval” Trade Waste Approval, which is designed for temporary settings.

The application will require details of the site location, how long required for, how we’re going to treat (Envirowash), and how are we going to get it to sewer. Charges based on projected volumes, \$152 application fee, charged every 3 months with a \$100 minimum. Once approved and in use, keep records of batch discharges. This application can be made via email to trade.waste@urbanutilities.com.au.

Greenfield projects can discharge treated water into their own site, provided care is taken to make sure it does not leave the site boundary

Dulux Envirowash

The most effective washout tool, but the largest containers can come at a cost of about \$2,400, and additional chemicals have to be bought to use the device. It is considered to be the simplest solution to set up, works effectively, and does not require pH testing.

The units are made up of two parts – the sink and a separate filtration tank. The units work by separating paint washings into clear water and solid paint.

The spray gun is used to wash rollers, brushes, paint trays, pots and anything else that has been used in the painting process.

Once the unit is full, treatment chemicals are used to separate the solid matter and water from the paint washings.

After 1-6 hours (depending on volume), clear water remains in the top of the tank and paint sludge is left at the bottom.

Clear water can be recycled into other trade related applications, or released onto flat grassy areas and gardens. Remaining paint sludge is filtered, ready for removal and drying.

Once residue is dry, it is ready to be disposed of as non-hazardous solid waste.

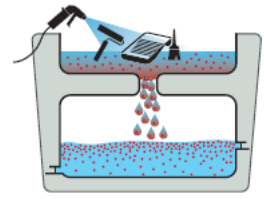

1. Wash painting equipment with spray gun

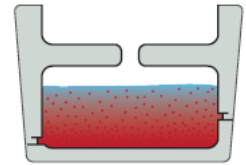

2. Filtration tank is full with paint washings

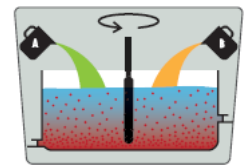

3. Chemicals are added to separate water and solid matter

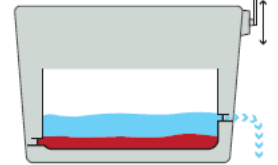

4. Clean water is released for reuse

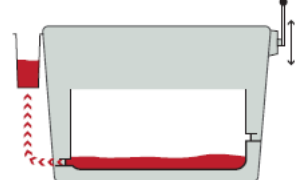

5. Sludge is pumped out of the tank and filtered



12.2 Sawcutting Backwash

Concrete sawcutting through footpaths should be supplemented with a resilient wet vacuum to control backwash and slurry. Block cutting backwash should be collected and disposed of into sewer.



13 Protection of Stormwater Infrastructure

13.1 Description

Protection of stormwater infrastructure is perhaps the simplest measure for Erosion and Sediment Control and should be applied on every project regardless of location.

On developed sites, such as in the CBD, protection of stormwater inlets may be the only ESC measure required.

Stormwater systems are particularly sensitive to an unnatural load of sediment deposits, so they must be monitored closely to ensure no sediment is tracking down the drain.

The type of control required depends on the situation. Note that in all applications, inlet grates are always wrapped in geofabric.

13.2 Establishment

On-grade Kerb Inlets – Sediment Trap

On-grade Kerb Inlets refer to inlets on the road where the road is sloping or on a gradient. These situations require sediment traps, or permeable dams, set up-slope of the inlet. They are composed of a layer of 2-3 sandbags or silt socks, with the middle piece of the top layer missing to create a spillway. This allows sediment to settle and run-off to crest over the spillway in the middle.

Note that sediment traps can't be placed across the face of an on-grade inlet—this will just mean the run-off will bypass the blockage and move to the next inlet.

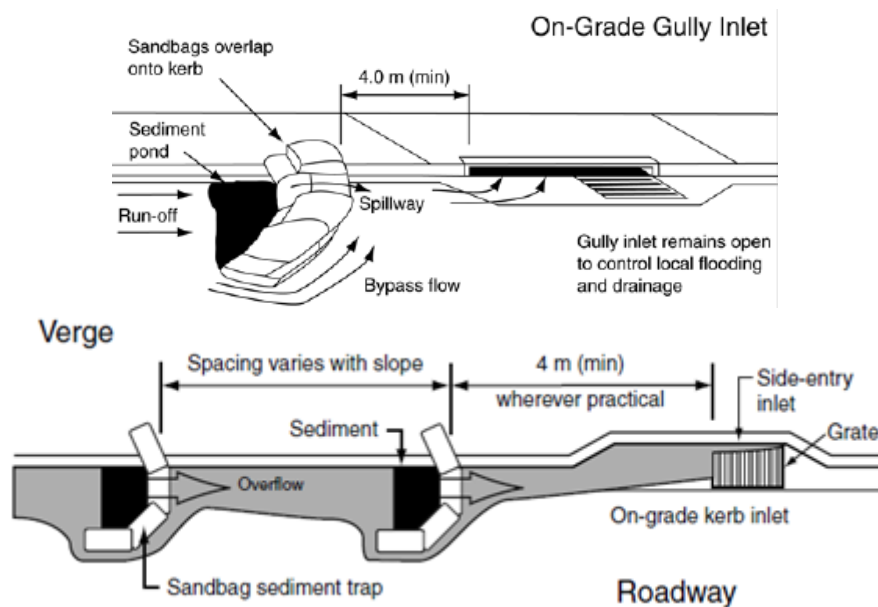



This is a good example of a silt-sock sediment trap at a 45° angle to the road working in concert with a catch-it. Water can be observed damming around the sock, settling out before flowing around it.

Facing the other direction, this image demonstrates visible ponding and settlement:



Sag Kerb Inlets

Sag inlets refer to inlets that sit on relatively flat road, sometimes inside a depression. They are distinguishable by grate situated in the middle of the inlet (as opposed to on-grade inlets which have the inlet to one side). Sag inlets should be completely enclosed by silt socks (aka gravel sausages) or sandbags, but not *blocking* the inlet opening.

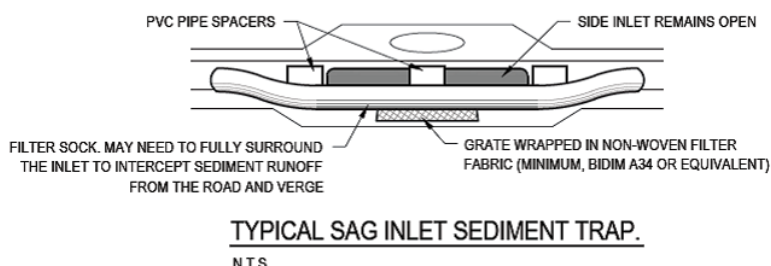

Slotted Pipe

Some projects may detail a slotted pipe to help capture sediment and litter before it enters the stormwater inlet. This should be used where active stormwater inlets are *in* the construction site, not outside of it, as it may unacceptably reduce drainage rates in significant rainfall.

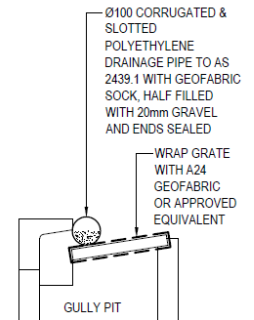

Gully Filtration Devices

If sediment traps like the ones shown above would cause a traffic hazard, via protrusion or ponding, alternatives should be considered. These alternatives (which are considered to be industry best practice) are resilient, perform better than the traps shown above, require very little maintenance, and are easy to install and monitor.

- Stormwater drain barrier/filter box, of a proprietary design such as the Catch-It. The advantage of these systems is that they are resilient and require very little maintenance or knowledge to install or monitor. At the time of writing they can be bought for \$420 or rented for \$10/week and it's suggested they pay for themselves with by reduction of labour required for maintenance.
- Drain warden/Gully filter Bag. Bags are 200 micron geotextile fabric. The bags are placed under the grate, with the grate pinning down the overhangs of the bag. Bags must be monitored and cleaned out regularly. The extra advantage of the drain warden is that it can be ordered to include an oil absorbent boom that traps hydrocarbons in run-off. At the time of writing they can be ordered for \$210.
- The Ecosol Litter Basket consists of a capture basket, an overflow by-pass flap(s), and a filter mesh liner. The basket is fitted below road invert and is visually unobtrusive. It claims to capture more than 97% of pollutants greater than 2000µm as well as fine sediments. Capable of 200µm filtration and doesn't required wrapping the grate. At the time of writing they can supplied and installed for \$550.
- 270gsm Dewatering Bag. Has a 90 micrometre (µm) pore size, so is capable of filtering for heavy particles. Possible applications are highly constrained site (i.e multi-story development). It would be characterized as a 'Type 2' sediment control device (better than sediment fence but not as good as a basin). Discharging water out of one of these bags is unlikely to achieve these water quality objectives – this is due to the fact that fine clay particles (the ones which cause runoff to be highly turbid) are smaller than 90 micron in diameter.

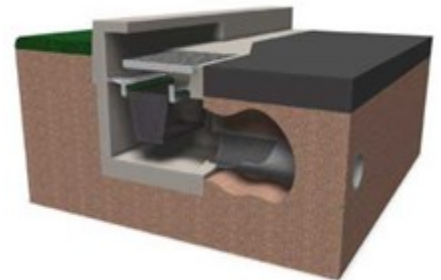

13.3 Monitoring

Inspect all kerb and inlet protection weekly, and immediately after storm events. Collected sediment should be removed spread or disposed of. Monitor if the ponding or sediment is creating a traffic hazard.

Ensure that the protection hasn't been broken, and replace it if it has been broken. Broken up sandbags or gravel bags spilling into the drain can be just as bad as no protection.

14 Grass/Turf Buffer zones

14.1 Description



Turf is considered the best form of sediment control. This is contingent on the level of cover the turf achieves. A minimum of 70% cover is considered stabilised and resistant to erosion, but turf must achieve a cover of 85% or above to be useful as a sediment filtration device.

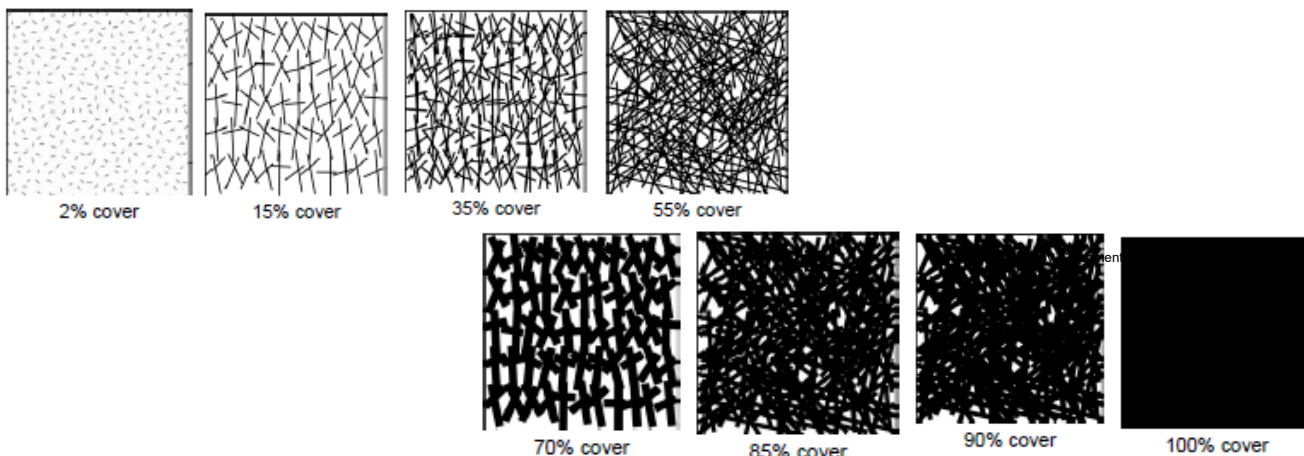

It is important to note the distinction between using turf as a filter and discharging onto turf. Turf can be used as a filter, but it must still exit the site in compliance with the discharge limits in Section 2.

Discharge volume and velocity must be taken into account to ensure that discharge is evenly and slowly spread so as not to damage the grass. There must also be a certain amount of distance to the nearest watercourse, if the turf is to be the last line of defence. This should be assessed by a qualified professional.

Natural grass cover can be relied on and can be seeded if the soil will support it. This may also require the use of breathable erosion mats or light mulching to protect from erosion while the seeds take root and sprout.

Turf tiles can also be laid. If turf is to be laid, note that it must not be placed on excessively compacted soils. It may require a bed of topsoil to take root. If high velocity flows are to be expected within the first 2 weeks, then the turf should be anchored in with wooden pegs.



Another alternative is hydroseeding, or hydromulching. Hydroseeding (or hydraulic mulch seeding, hydro-mulching, hydraseeding) is a planting process that uses a slurry of seed and mulch. The slurry is transported in a tank and sprayed over prepared ground. The slurry often has other ingredients including fertilizer, tackifying agents, fiber mulch, and green dye. Results are often quick with high germination rates producing grass growth in about a week and mowing maintenance beginning around 3–4 weeks from the date of application. At the time of writing this can cost \$1/m².

14.2 Establishment

Establishment methods are as described above and will depend on the manufacturer's installation specifications.

14.3 Monitoring

Monitor all turf and grass to ensure erosion is not occurring, and run-off is clean.

15 Erosion Protection and Dust Control

Dust can be very difficult to control. Ideally, the opportunity for dust to arise should be minimised with things like staging and erosion protection.

In situations where soil has to be exposed for extended period, the following methods of dust control can be used.



15.1 Water Carts

Water carts are the most commonly seen form of dust suppression on commercial construction sites. During hot dry weather, the surface layer is rarely effective for long periods.



15.2 Road Base

Road base for haul roads should be considered. Overburden material, or similar, could be used as a blanket course for the haulage road. The working layer may be a crushed concrete type material, large size gravel or an imported sub-base material. This is arguably the most effective treatment for stopping sediment leakage onto roads. CBR25 can be used, rolled and compacted, wet 4-5 times per day depending how hot it is. It may require occasional skimming across the top to clear mud.



15.3 Soil Surfactants/Bio-Polymer Membrane

Liquid stabilizers and polymers provide dust suppression and stronger surface course. Common suppressants include:

- Emulsified asphalt
- Calcium chloride
- Calcium lignosulfonate
- Soil Surfactants

Bio-polymer membranes, such as Vital Chemical’s Stonewall, can be applied by bottle or by water-cart. It can be applied to stockpiles, batters, swales, or exposed areas.

It protects against wind and rain, is (lightly) trafficable, causes no environmental harm, and biodegrades over months. Once it’s cast, you never need to think about it again. One coat lasts up to a year.



Vital Chemical also have a product called Haul Roads, which also creates a biodegradable membrane, designed for heavy plant traffic.



15.4 Erosion Protection

Exposed areas can be stabilised through a layer of mulch (left) or erosion matting, e.g. jute mesh (centre and right).



15.5 Sprinklers

Some sites may use sprinklers to saturate the top layer of soil at night to inject moisture, or as needed to reduce dust.



16 Working In And Around Watercourses

16.1 Description

Natural watercourses and bodies such as rivers, creeks, lakes etc are more susceptible to erosion damage as the sediment discharge will directly impact the water body.

As such, it is important to keep in mind the damage that can be done and work as sensitively as possible.

Disturbances to the banks of rivers and creeks can also be very difficult to re-stabilise and rehabilitate to the due constant bombardment from the natural flow.

16.2 Establishment



Erosion and Sediment Controls around watercourses should be established either by hand, or with as much distance as possible from the banks.

Avoid clearing or damaging natural vegetation on the banks as much as possible. Where this is unavoidable, aim to minimise the disturbance. Do not disturb natural vegetation until sediment control measures are in place. Avoid using plant and equipment within the actual water body where possible.

Off-Stream Isolation



Isolation barriers such as the one pictured can be used to protect destabilised banks from the natural water flow while the bank is stabilised.

The adjacent image is an example of the sediment fence against the bank, with a woven fabric fence forming a fine sediment settling pond.

These can be formed from sediment fence fabric, floating silt curtains, large water-filled rubber dams, and sheet piling.

On-Stream Sediment Control

Downstream sediment control is considered to be of secondary function. They are designed to sit within dry weather flows and filter the stream. This can be achieved via rock filter dams (shown below), sediment fence weirs (shown below), or filter tubes/blocks. This should ideally be designed by an expert as they may interrupt fish migration.



Bank Rehabilitation

Priority must be given to stabilising disturbed banks. This can be achieved through rock bedding, erosion mats or vegetation.

16.3 Monitoring

Monitor banks for erosion and controls for sediment build-up.

17 Emergency Inundation

17.1 Storm events

Heavy rainfall may catch sites off guard, and significant storm events may inundate the site. Ideally, storm preparation and overflow allowances may protect against this, as Council inspectors will not expect site level controls to compensate for 1 in 100-year storm events.

However, if residual ponding is present on site, it is incumbent on Watpac to manage its responsibility. Several options include:

17.2 In-Situ Flocculation and Pumping

Often the easiest scenario is to treat the water in-situ, and pump out. To expedite this process, remove the need to experiment, water quality experts (e.g. Turbid) can be called out to perform a jar test and work out the most effective product to use.



BESIX Watpac have had recent success using the product “Turbiclear”, as it takes effect without much active stirring (perfect for the situation above where water is not concentrated into one area and stirring is difficult). The product was spread by using a flexdrive pump, leaving the submersible submerged in shallow water, and tipping the product into the intake to recycle it through a lay-flat hose and hose attachment.



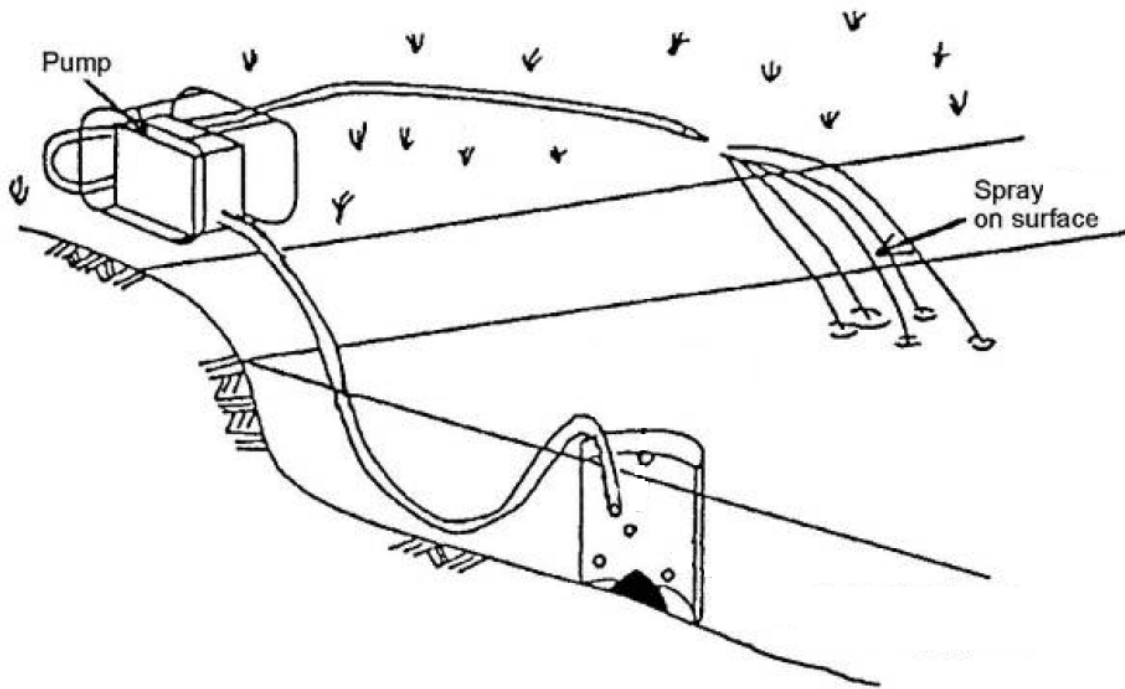

Once the product has taken effect, you can then start testing to see if the water quality is achieved.

17.3 Localised Sump Pits

For projects that have been inundated during groundworks, an effective strategy has been to dig localised sump pits with drains and falls, concentrating the water into pools that can then be pumped into the sediment basin or treated in-situ as the pools. If lift pits have been dug, they may be used for this purpose.



17.4 Liquid Waste Disposal

A Liquid Waste Disposal Contractor can be engaged to vacuum up the water. Indicative fees are \$0.15/Litre (\$0.40 if highly contaminated), or \$140/hour with a minimum call-out of 3 hours (\$420) and a disposal fee of \$0.07/L (so, \$1,400 per 20,000L truck). A 20,000L fills up in less than an hour.



17.5 Trade Waste Agreements

More commonly in Victoria, Trade Waste Agreements can be established with the wastewater service retailer to discharge unclean water into the sewer.

In Queensland, the Water Act in in Water Safety & Reliability Act prohibits stormwater or groundwater from being deposited into sewer, as they are Prohibited Substances under this Act. There is some exception to this which may be granted under certain circumstances, such as seepage water (defined as water seeping into structure).

18 Chemical Storage

Chemicals should be stored in a lockable container, with a grated bunded floor that offers 110% of the volume being stored. Containers should ideally be vented to allow air escape. An example of this is provided below.



19 Water Quality Testing

19.1 Operation

Watpac typically use the Yeokal meters. Yeokals are designed to be as user friendly as possible. Simply attach the probe to the 'sensor' input, submerge the probe into water, and turn the unit on. It will automatically display the readings on the unit which can be scrolled through using the up and down arrows.

To avoid the trouble of downloading the data, it is recommended that data be captured on a Water Meter Report Card (E-FRM-005). The advantage of using the report card is that it includes relative discharge limits and information to provide indicative perspective on the readings of the meter.

If the readings are outside of acceptable limits, issue the report to the State Environmental Manager for their consideration. An investigation into the possible cause should be undertaken, and corrective measures should be trialled before engaging a Consultant to complete a detailed review.

19.2 Testing Intervals

Watercourse testing should be undertaken at intervals prescribed by the Project Environmental Management Plan (PEMP), or by the project specifications. Where no intervals are prescribed, it should be conducted monthly by default. To address requirement B25j, prior to discharging water from site into the stormwater infrastructure on driver avenue Section 6.1.3 General Recommendations of the Managing Urban Stormwater – Soils and Construction Volume 1 (4th Edition March 2004) should be followed. As outlined in Section 6.1.3 dewatering activities should be closely monitored to prevent pollution in the form of sediment, toxic materials or petroleum products. Sediment controls should be established and testing of ground water should be undertaken before commencement of dewatering activities. To address requirement B25k, methods of evaluating the water quality testing results are to be completed by a suitably qualified water quality expert.

Water meter testing will only be required on projects where it is called for in the PEMP or project specifications. It may also be undertaken excursively by the Environmental Manager in response to particular concerns or at their discretion.

19.3 Test Points

The PEMP or project specifications should nominate where test points.

For Sediment Basin monitoring, the meter probe should be submerged to an appropriate depth to get a sampling truly representative of water quality. That should be approximately half the depth of the basin. Tests should be done after storm events or when the water level is above the sediment storage zone (and therefore is time to empty the basin).

In situations where we are discharging into a watercourse, there will generally be 2 or 3 points, as applicable to the arrangement of the site:

- Discharge Point: testing the water quality at the point where it leaves the site. This can either be the water on the site, immediately after or prior to leaving the site and mixing with the receiving environment (ideal), or the point at which the discharge intermingles with the receiving environment.
- Upstream Point: testing the water quality upstream provides a control sample of the natural environment prior to any interference that may be caused by our activities. This is an important reference point, particular against limits such as turbidity.
- Downstream Point: This is considered optional but may be specified. Necessary on sites in coastal locations, where the bay does not have a continuous flow direction. It can also be useful in determining

the net effect of our discharge on the receiving environment and can also be useful in detecting another source of pollution that may be separate to the discharge point.

20 Phases of the works

It is recommended that the ESC plan be regularly marked up during each of these phases to display and plan their progress.

Any soil disturbance is considered a risk, and staging the works to minimise concurrent disturbance is ideal. Site compounds and heavily trafficked areas should be stabilised with roadbase or polymer membrane.

20.1 Clearing and Rehabilitation

Earthworks must be planned so that the total area disturbed and the total time it is disturbed are minimised. The absolute maximum times that areas are allowed to be left disturbed, after either completion of earthworks in an area or when an area is not actively worked, are described below. The erosion risk should be provided in the PEMP or in the Geotechnical Report.

Table 2 [Insert Table Caption]

Erosion Risk	Soil Loss Rate (t/ha/year)	Advanced Land Clearing Allowed (weeks)	Max days to stabilisation	Stockpiles stabilised
Very Low	0 to 150	8	30	
Low	150 to 225	8	30	
Moderate	225 to 500	6	20	
High	500 to 1500	4	10	✓
Extreme	>1500	2	10	✓

“Advanced Land Clearing Allowed” means the number of weeks in advance of commencing bulk earthworks that can clear and grubbing can be undertaken, *providing all Erosion and Sediment Controls are in place*.

“Max days to stabilisation” is the period from completion of earthworks to achieving stabilisation (i.e. through either permanent landscaping or revegetation). With relatively short periods (30 days or less) practices such as spreading topsoil and seeding are unacceptable as grass will not establish sufficiently within this period to consider lands stable. Advanced temporary stabilisation measures will be required, such as light mulch or erosion matting (jute or coir mesh).

“Stockpile stabilisation” is weather protection of stockpiles, required for highly or extremely erosive soils.

Exposed soil surfaces must be rehabilitated as soon as practical to minimise the risk of erosion and the resulting environmental harm. To be effective, at least 70-80% cover must be achieved in order to protect the soil surface from raindrop impact. Soil surfaces that have been significantly compacted during construction must be scarified/ripped prior to revegetation. Existing soils may require testing and adjustment before reusing.

20.2 Operation

The operational phase refers to the Construction stage of the project. This is the time when the erosion and sediment controls are in operation and require monitoring and servicing. During this time a weekly inspection should be undertaken with the Environmental Inspection Checklist (E-FRM-001). If sediment basins or water monitoring is required, form E-FRM-005 should be used at the same time.

The Erosion and Sediment Control Plan should be kept up to date with mark-ups that reflect any changes in locations or circumstance.

20.3 Site Closure

Procedures for initiating a site shutdown, whether planned or unplanned, must incorporate the revegetation of all soil disturbances. Revegetation activities associated with a programmed site shutdown should commence at least 30 days prior to the nominated shutdown date.

Non-vegetated erosion controls such as mulch, blankets and soil binders can be used if the shutdown period is for less than 3 months. Priority should be given to revegetation before short-term shutdowns. Future garden beds should be protected with heavy mulching. Mulch must also be protected from leaving site. Access to site should be limited to reduce risk of rubbish dumping and soil disturbance during the closure period.

The following activities should be undertaken ahead of a temporary site shutdown, including the Christmas break.

- Minimising soil disturbance. Ensure there is no exposed soil. Where this is not possible, stabilise with erosion mats or mulch.
- Maintaining site access. Ensure the vehicle entry/exit grids are cleaned out.
- Sediment fencing. Walk the extent of the fencing and correct any gaps or breakages.
- Clean up litter and waste. Clean the work area to ensure that rubbish and other materials are not transported outside the works in the wind or water flow.
- Stockpiles. Ensure stockpiles are enclosed by sediment fencing and protected from weather.
- Sediment Basins – Projects with sediment basins should ensure the basins are completely cleaned out and ready for a storm event.

21 Soil Characteristics

Apart from erosion risk, different soil types and texture can affect water quality management and each has their various risks.

Soil texture (such as loam, sandy loam or clay) refers to the proportion of sand, silt and clay sized particles that make up the mineral fraction of the soil. For example, light soil refers to a soil high in sand relative to clay, while heavy soils are made up largely of clay. Soil type and texture will be identified in the geotechnical report.



Colour can be a useful indicator of some of the general properties of a soil:

- Black— from organic matter, usually low permeability, may have low pH, low oxygen
- Brown— from organic matter, usually high permeability, may have low pH
- Red or Yellow— from iron and aluminium oxides, highly permeable, possibly acidic on exposure to oxygen
- White— from silicates and salt, highly permeable
- Green or Grey— very poor drainage, methane emission hazard

Plasticity refers to its cohesiveness; soils with a high plasticity tend to be clay, those with a lower plasticity tend to be silt, and non-plastic soils tend to have little or no silt or clay. High plasticity can indicate low permeability and mud.

Porosity refers to the portion of volume of a material that consists of open space; clay and sand are about the same (saturation point of 30-40%). Permeability is the speed at which water can move through a medium.

Below is an indication of the various permeability of differing soil types:

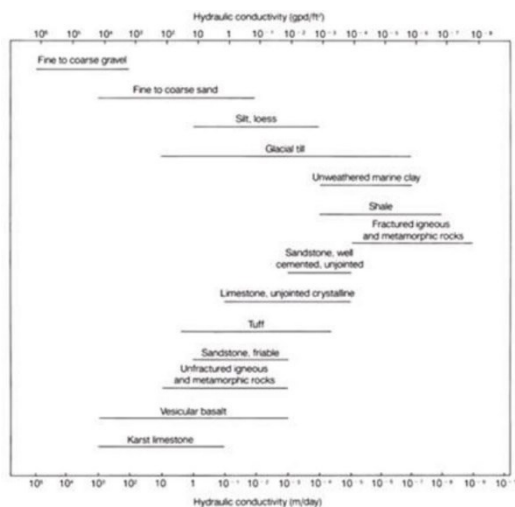

21.1 Alluvium

In geotechnical reports, Alluvium refers to a layer of alluvial soil, which is simply “material deposited by water moving across the land surface”. Alluvium is loose and unconsolidated, which has been eroded, reshaped by water in some form, and redeposited in a non-marine setting. Alluvium is typically made up of a variety of materials, including fine particles of silt and clay and larger particles of sand and gravel. When this loose alluvial material is deposited or cemented into a lithological unit, or lithified, it is called an alluvial deposit.

21.2 Clay (Cohesive soils)

Clay soils generally hold more water and are better at supplying nutrients. The heavier the clay, the lower the permeability (the heaviest can mean low oxygen). Clay has high susceptibility to mechanical compaction. Clays saturate easily and can turn to mud in rainfall events, which may necessitate the use of a washbay at the vehicle entry/exits of the site. Low permeability can also mean reduce ingress of tidal groundwater. It is considered a heterogeneous mixture of various grades of materials.

21.3 Sand (Granular soils)

You can easily see the individual particles and water drains quite easily from them. High bearing capacity and extremely high permeability; high winds can cause abrasive dust. Useful for recharging groundwater into and has low overland flow. The relatively ‘loose’ nature of the sands and the very soft clays, combined with the potential inflow of ground water, are difficult excavation conditions and may necessitate diaphragm or secant pile walls. Sheet Piles can be considered but will need to be propped/anchored. It is considered a homogeneous mixture of fairly consistent grading, which attributes it’s permeability.

21.4 Indurated Sands (Coffee Rock)

Sand below the groundwater table is denser, poorly sorted, and includes lenses of cemented sand. These indurated sands (coffee rock) influence groundwater resources due to reduced porosity, flow velocities, and forming perched water tables. Indurated means hardened.



21.5 Loam

When soil is not predominantly sand or clay, it is called "loam". In Queensland loam is often sodic, meaning it has high sodium ions, causing dispersion when wet and crusting when dry. It is prone to displacement by water or dust.



21.6 Topsoil

Usually referred to as the A horizon where most plants, roots, earthworms, insects and microorganisms are active. Organic soils can't be compacted and must be removed and replaced with a compressible fill where they support structural elements.

21.7 Fill

Fill is basically any extra soil, gravel or other material on the site that either has no distinctive origin or records. In the absence of fill certification as ‘Level 1’, fill material is classified as ‘uncontrolled’. Uncontrolled fills can range from compacted engineered fills where no construction records exist, to a heterogeneous mix of soil types, organics, boulders, construction debris, trash, industrial waste, and contaminants. It is possible Asbestos Contaminated Materials (ACM) may be found in layers of fill.

21.8 Acid Sulfate

Acid Sulfate Soils (ASS) are naturally occurring sediments and soils containing iron sulphides or sulphidic materials, often located over extensive low-lying coastal areas, predominately below RL 5mAHD. These soils are generally found close to the natural ground surface, but may also be found at depth within the soil profile.

ASS includes Actual Acid Sulphate Soils (AASS) and Potential Acid Sulphate Soils (PASS). AASS and PASS are often found within the same soil profile, with AASS generally overlying PASS. AASS are soils containing highly acidic soils resulting from the oxidation of soil materials that contained sulphides. PASS are soils that contain iron sulphides or sulphidic materials, which have not been oxidised.

Screening process

- Soils are usually “screened” to isolate areas of interest to test for. pH_F and pH_{FOX} indicate possible actual acid sulfate soils (AASS) or potential acid sulfate soils (PASS) .
 - pH_F — measure of soil pH of a soil:water paste. $pH_F < 4$ indicates oxidation has occurred in the past and that AASS is present.
 - pH_{FOX} — measure of soil pH after rapid oxidation with hydrogen peroxide (H_2O_2). $pH_{FOX} < 3$, plus a pH_{FOX} reading at least one pH unit below pH_F , plus a strong reaction with peroxide, strongly indicates the presence of PASS.
 - Effervescence (or reaction rate) — a visual measure of the vigorousness of the oxidation reaction where: 1 = slight; 2 = moderate; 3 = high; and 4 = extreme.

pH_F	pH_{FOX}	ΔpH	Reaction Rate	Action required
≥ 5.0	≤ 5.0	≤ 2	1-2	If no other field indicators or acid sulfate soil risk indicators are present, no further action is required
> 4.0 and < 5.0	> 3.0 and < 5.0	> 2	≥ 2	PASS may be present, further assessment is required
≤ 4.0	≤ 3.0	> 2	≥ 2	AASS or PASS are likely to be present, further assessment is required

Assessment Process

- Lab tests are the only truly definitive way of measuring for actual or potential acid sulfate. This is done by the SPOCAS or Chromium Suite method.
- The SPOCAS suite is effective for coarser textured sediments.
- The Chromium Suite (aka SCR suite) is effective for assessing soils with lower percentages of sulfide and for soils containing organic material.
- Chromium reducible sulphur values (SCR) greater than 0.01% S indicate a significant level of sulphides, and where greater than 0.03% S then the soil has a high potential acidity level and an Acid Sulfate Soils Management Plan will be required.
- Net Acidity (TAA + SCR + SNAS – ANC/1.5) of greater than or equal to 0.03% S for soils, for greater than 1000 tonnes of disturbance.

Soil or sediment texture ¹	Approximate clay content (%)	Net acidity criteria (1-1000 tonnes)		Net acidity criteria (>1000 tonnes)	
		(%S) (oven-dry basis)	mol H ⁺ /tonne (oven-dry basis)	(%S) (oven-dry basis)	mol H ⁺ /tonne (oven-dry basis)
Sands to loamy sands	< 5	0.03	18	0.03	18
Sandy loams to light clays	5-40	0.06	36	0.03	18
Medium to heavy clays and silty clays	> 40	0.1	62	0.03	18

(Source: Acid Sulfate Soils Technical Manual: Soil Management Guidelines, 2002)

- Moderate levels of potential acidity = 0.008 %S to 0.235%S
- High potential acidity = <0.02 %S to 0.41%S

21.9 Iron and Aluminium Concentration

A high aluminium concentration (over 50 ug/L) in groundwater indicates whether Acid Sulfate Soils are likely to have been oxidised. Use of Aluminium based flocculants may result in elevated dissolved aluminium concentrations in the post-treated effluent.

Iron concentrations in groundwater are considered high at around 500ug/L, where they can cause precipitation, staining and clogging in dewatering and drainage systems. At 1000ug/L, water is likely to cause precipitation and iron-oxides on exposure to atmospheric oxygen. Oxidation or neutral pH in high iron concentrations can cause iron floc (looks like red ooze) which, while not harmful, can cause turbidity issues. Iron floc can be flocculated out— this floc can be collected by a waste contractor.



Anecdotal indicators of acid sulfate include:

- Sulfuric smell (rotten eggs)
- Red or yellow discolouration at the banks of water
- Yellow mud or rock-powder in clayey mud
- Yellow water

22 Groundwater Management

22.1 Dewatering

Any water being discharged from site will require some assurance that the water quality is sufficiently healthy. Groundwater extracted from problematic soil (mentioned above) may require additional treatment and testing, for example to balance the pH or extract heavy metals.

Specialised dewatering companies, or Hydrogeologists, should be engaged to plan, implement and monitor dewatering effectively on sites with groundwater issues. Options are either a localised sump and pump array, or a spear dewatering system. Spears may not be an option for certain where nearby displacement could lead to cracking or bubbling in roads and pavement, e.g. where the soil is highly reactive or saturated. Site Movement Monitoring will likely be required.

The geotechnical report will identify the risks around groundwater and will often nominate where a dewatering plan is required. Occasionally these reports will include groundwater bores which can indicate the level of inflow expected; note that this can be misleading as perched groundwater in clay can cause an initially huge inflow but has minimal long-term tidal inflow.

In situations where there is a high water table and permeable material such as sand, it is expected that groundwater inflow into the excavation will be significant and require a cut off sheet pile wall with internal dewatering system to construct the basement structure in “dry” conditions.

22.2 Heavy Metals

Trace amount of detectable heavy metals are considered acceptable in discharge. Guidelines for heavy metals are generally taken from the ANZECC 2000 guidelines for freshwater or marine ecosystems. The ones for marine are provided below and relate to a site where the water is discharged to the Brisbane River or to the coastline. The guidelines used depend on where the water is going to be discharged to.

Table 3 [Insert Table Caption]

Pollutant	Freshwater Discharge Limit	Marine Discharge Limit
Aluminium (pH >6.5)	0.5 ug/L	0.5 ug/L
Arsenic	13 ug/L	13 ug/L
Cadmium	0.2 ug/L	0.7 ug/L
Chromium	4.4 ug/L	4.4 ug/L
Copper	1.3 ug/L	1.3 ug/L
Iron	300 ug/L	300 ug/L
Lead	4.4 ug/L	4.4 ug/L
Manganese	1900 ug/L	1900 ug/L
Nickel	11 ug/L	7 ug/L
Zinc	8 ug/L	15 ug/L

Decreases increases in pH will dissolve metal-carbonate complexes, releasing free metal ions into the water column. This can be used to filter out heavy metals, and may be used in conjunction with carbon filtration.

Inversely, a high pH can increase in the concentration of insoluble metals from the dissolved form present in surrounding soil.

Carbon filtration is introducing a layer of activated carbon (e.g. charcoal), a form of carbon processed to have small, low-volume pores that increase the surface area available for adsorption or chemical reactions.



22.3 Acid Sulfate Groundwater

Generally, groundwater in acid sulfate soils won't be acidic unless the soil has turned acidic, which is on exposure to oxygen. Therefore, groundwater expression in undisturbed and saturated soils isn't likely to be acidic. However, after dewatering operations have occurred and oxygenated the soils below ground, groundwater recovery should be considered acidic.

22.4 Groundwater Expression

Depending on the depth of the groundwater to the surface level, groundwater can express up through the surface in heavy enough rains and/or tidal inflow. These two factors are unlikely to account for more than a few hundred millimetres. In situations where impermeable soil has confined perched groundwater, high pressure (such as heavy plant) can cause groundwater to express.

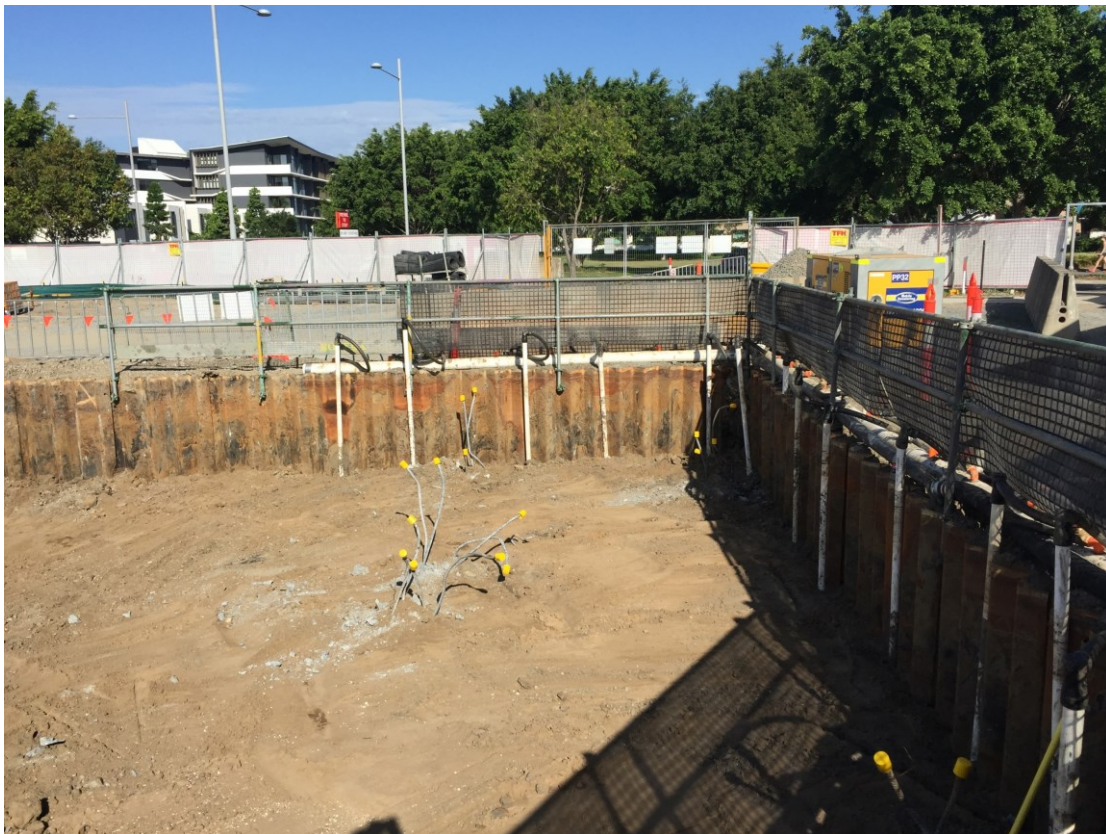

23 Environmental Constraints

23.1 Erosion Hazard

The Erosion Hazard is calculated using the Revised Universal Soil Loss Equation (RUSLE) formula. RUSLE can be expressed as follows:

$$A = R * K * LS * C * P$$

Where

A = estimated average soil loss in tons per acre per year

R = rainfall-runoff erosivity factor

K = soil erodibility factor

L = slope length factor

S = slope steepness factor

C = cover-management factor

P = support practice factor

This calculation should be performed by a qualified professional.

23.2 Staging

Any soil disturbance is considered a risk, and staging the works to minimise concurrent disturbance is ideal. Site compounds and heavily trafficked areas should be stabilised with roadbase or polymer membrane.

23.3 Season and Climate

Wet or dry seasons can have a huge impact on erosion risks. Earthworks, clearing and grubbing should ideally be staged during the dry seasons of the year as much as possible.

Climate can also affect erosion risk, as it can vary the impact of rainfall, and moisture support to groundcover. Climate will be factored into the RUSLE equation as an ancillary consideration.

23.4 Proximity to Waterways

The proximity to waterways is an important consideration. If the works are to take place on or very near waterways, extra controls will be needed. Refer to section 14, "Work in and around watercourses". If discharge to occur over a turf buffer zone, the buffer zone needs to be long enough to provide sufficient filtration before hitting a watercourse. This should be designed by a suitably qualified professional.

23.5 Controls outside of Site

Controls outside of the site cannot be relied upon, as stated by the IECA guidelines.

On a related note, run-off cannot be diverted into neighbouring properties. Note that this applies to disruptions to the natural overland flow. Unnatural disruptions and run-off must be captured, and responsibility discharged into stormwater or a natural watercourse without impacting neighbouring properties.

24 Bibliography

24.1 References

The following sources were referenced in collating the information:

- Catchments and Creeks Pty Ltd, “Erosion and Sediment Control – A Field Guide for Construction Site Managers”
- Healthy waterways.org
- DEHP stormwater guidelines EM368
- O2 Engineering Sediment and Erosion Control Training Manual

24.2 Images

Any photos that are uncredited were captured by Watpac.

Section 1

1. Types of Erosion: <http://extension.missouri.edu/p/G1509>
2. Comparison of coarse sediment, clay and sand: www.catchmentsandcreeks.com.au/FS/OST-1.pdf
3. Gold Coast Aquatic Centre, Watpac Network Folders

Section 2

4. Examples of Total Suspended Solids: O2 Engineering ESC Training Manual
5. Comparison of coarse sediment, clay and sand: www.catchmentsandcreeks.com.au/FS/OST-1.pdf
6. Turbidity examples: <http://ga2.er.usgs.gov/bacteria/helpturbidity.cfm>
7. pH Scale Health of fish: <http://extension.usu.edu/waterquality/hm/whats-in-your-water/ph>

Section 3

8. Type 3 Control - Sediment fence: <http://www.aussieerosion.com.au/>
9. Type 3 Control: Inlet protection: www.catchmentsandcreeks.com.au/FS/samples/SA-2.pdf
10. Type 2 Control: Rock filter dam: Catchments and Creeks Pty Ltd, “Erosion and Sediment Control – A Field Guide for Construction Site Managers”
11. Type 2 Control: rock filter dam (photo): www.catchmentsandcreeks.com.au/FS/STG-1.pdf
12. Type 3 Control: Sediment Basin: O2 Engineering ESC Training Manual
13. Type 3 Control: Sediment Basin Filter Diagram: www.sca.nsw.gov.au/catchment/living/.../during-construction

Section 4

14. Sediment Fence Section Graphic: O2 Engineering ESC Training Manual
15. Sediment Fence detail: Structural drawing
16. Sediment fence layouts: IECA Guidelines

Section 5

17. Stockpile enclosure: www.austieca.com.au/documents/item/430
18. Stockpile Leakage: www.catchmentsandcreeks.com.au/FS/SPM-1.pdf
19. Stockpile badly placed with no protection: Catchments and Creeks Pty Ltd, “Erosion and Sediment Control – A Field Guide for Construction Site Managers”

Section 6

20. Coir log: www.thegroundworkgroup.com.au/environmental-1.html
21. Silt sock berm: www.gillilandlandscape.com/compost-silt-sock
22. Diversion drain: Standard structural drawing

Section 7

23. Swale drain: Catchments and Creeks Pty Ltd, “Erosion and Sediment Control – A Field Guide for Construction Site Managers”
24. Rock check dam section graphic: O2 Engineering ESC Training Manual
25. Rock check dam detail: Structural drawing
26. Temp swale detail: Standard Structural Drawings

Section 8

27. Rock Chute: www.catchmentsandcreeks.com.au/.../Rock-Sizing-For-Drainage-Channels.pdf
28. Turf Chute: www.catchmentsandcreeks.com.au/docs/Gully2-1.pdf
29. Scour Protection after culvert: O2 Engineering ESC Training Manual

Section 9

30. Sediment Trap: IECA Guidelines
31. Sediment Trap photo: <http://cfpub.epa.gov/npdes/stormwater/menuofbmps/index.cfm?action=browse&Rbutton=detail&bmp=59>
32. Type 2 Control: Rock filter dam: Catchments and Creeks Pty Ltd, “Erosion and Sediment Control – A Field Guide for Construction Site Managers”
33. Field inlet sediment trap sketch: unix.eng.ua.edu/~rpitt/Workshop/.../Module8/Module8.htm
34. Field inlet sediment trap photo: www.mackay.qld.gov.au/.../Appendix_E_-_MCC_Work_Procedures.pdf
35. Concentred flow trap: O2 Engineering ESC Training Manual

Section 10

36. **Sediment Basin:** Catchments and Creeks Pty Ltd, “Erosion and Sediment Control – A Field Guide for Construction Site Managers”
37. **Section of sediment basin: IECA Guidelines**
38. **Construction of a sediment basin:** www.brisbane.qld.gov.au/.../wsud_chapt4.1_to_4.3.3_sedimentation_basins.pdf
39. **Example of the effect of flocculant:** Catchments and Creeks Pty Ltd, “Erosion and Sediment Control – A Field Guide for Construction Site Managers”

Section 11

40. **Entry grid:** www.catchmentsandcreeks.com.au/FS/samples/V-Exit-2.pdf
41. **Sediment traps around entry: IECA guidelines**
42. **Medium Speed wash-bay: IECA guidelines**
43. **Street Sweeper -** www.caticgz.com/Products/2675.html

Section 12

44. Lined washout: <http://www.nebraskah2o.org/wp-content/uploads/2011/11/concrete-washout-good.jpg>
45. Plastic lined skip:
<http://cdn.instructables.com/FTJ/CM4S/FXA2ONET/FTJCM4SFXA2ONET.LARGE.jpg>

Section 13

46. On-Grade Inlet Protection: ecan.govt.nz/advice/.../EandSCG_SmallSiteGuideline.pdf
47. On-Grade inlet protection (in plan): IECA guidelines
48. Inlet protection: www.catchmentsandcreeks.com.au/FS/samples/SA-2.pdf
49. Catch-it Silt protection system: www.catch-it.com.au
50. Drain Warden: spillsolutions.co.nz/drain-protection.php

Section 14

51. Turf: <http://www.lawn-care-academy.com/buffalo-grass.html>
52. Comparisons of coverage: Catchments and Creeks Pty Ltd, “Erosion and Sediment Control – A Field Guide for Construction Site Managers”
53. Turf tiles: Catchments and Creeks Pty Ltd, “Erosion and Sediment Control – A Field Guide for Construction Site Managers”
54. Hydroseeding: <http://www.countrylawnsapes.com/services/hydroseeding/>

Section 15

55. Plant away from waterbody: Catchments and Creeks Pty Ltd, “Erosion and Sediment Control – A Field Guide for Construction Site Managers”
56. Stream Isolation Barrier: Catchments and Creeks Pty Ltd, “Erosion and Sediment Control – A Field Guide for Construction Site Managers”
57. Rock filter dam: Catchments and Creeks Pty Ltd, “Erosion and Sediment Control – A Field Guide for Construction Site Managers”
58. Sediment weir: Catchments and Creeks Pty Ltd, “Erosion and Sediment Control – A Field Guide for Construction Site Managers”

24.3 Disclaimer

The document is intended solely for internal use by Watpac. It is designed to act as a guide to interpreting Erosion and Sediment Control Plans. It contains Watpac’s preferred methods for ESC in situations where no specific control measure has been detailed. It must not be distributed externally or used to represent Watpac as experts in Erosion and Sediment Control for commercial purposes.

The advice of Erosion and Sediment Control experts, Civil Engineer, Superintendent or the like will take precedence over anything contained in this document. However, reasoned discussion is encouraged, and this guide can be referred to (which in turn is derived from the IECA guidelines and the Catchment and Creeks Field Guide).

Photos and directions are provided courtesy of publicly available sources such as Catchments and Creeks Pty Ltd. Consultants such as these are considered experts in erosion and sediment control.

Appendix D – Curriculum Vitae of Suitably Qualified Expert (as per Condition B25a)

Curriculum Vitae for Andrew Littlewood

Profession Senior Soil Conservationist. Certified Professional in Erosion and Sediment Control (CPESC). Certified Erosion, Sediment and Storm Water Inspector (CESSWI)

Business Rubicon Enviro Pty Ltd - Principal & Managing Director - ABN 75 616 518 211

Mail: P O Box 7111 Redhead NSW 2290

Mobile: 0429 953 626

Email: andrew@rubiconenviro.com.au

Web <https://rubiconenviro.com.au/>

Qualifications and Occupational training

2023	EnviroCert International - Certified Erosion, Sediment and Storm Water Inspector No. 12101
2020	IECA Australasia – Approved Examiner for Certified Professional in Erosion and Sediment Control (CPESC) Assessment – Final Component: ‘Practical Take Home Exercise’
2014	Roads and Maritime Services - ‘Worker on Foot’ Construction Safety Training
2013	EnviroCert. & IECA Australasia - Certified Professional in Erosion and Sediment Control - No. 5988
2010	EnviroCert & IECA Australasia - Certified Professional in Erosion and Sediment Control – Associate No. 5988
2009	SEEC and IECA (Australasia) – ‘Water Management on Construction sites’ & ‘Preparing and Reviewing Plans for Soil and Water Management’.
2009	SEEC and IECA (Australasia) - Erosion and Sediment Control for Main Road Construction
2008	CERT - Centre for Excellence in Rail Training - Rail Industry Safety Induction
2008	Forgacs Engineering Pty Ltd - Confined Spaces Awareness
2007	New South Wales Master Builders Association and Gems Pty Ltd - Certificate in Erosion and Sediment Control Management
2006	WorkCover New South Wales - Occupational Health and Safety Induction Training for Construction Work
2003	Out of Town 4WD Driver Training Pty Ltd - Certificate III in Outdoor Recreation SRO 30299 - Four wheel driving techniques
2000	Lower Hunter and Central Coast Regional Environmental Management Strategy (LHCCREMS) - Certificate of Achievement in Water Sensitive Urban Design
2000	University of Western Sydney and Hawkesbury Global Ltd - Certificate of Attainment in Soil and Water Management for Urban Development
2000	Education Design Systems Pty Ltd - Investigative Interviewing Techniques
1997	Office of the Sheriff of NSW - Two way radio communication and protocol, and Basic First Aid including resuscitation
1988 - 1990	NSW Solicitors and Barristers Admissions Board Course

Curriculum Vitae for Andrew Littlewood

Professional Affiliations

2008 - present Member of International Erosion Control Association (Australasia)

Employment history

Company T.R.E.E.S. Pty. Ltd. - 2008 to 2016

Position Senior Soil Conservationist & CPESC

- Responsibilities:
- Co-ordinating company activities and client liaison for the New South Wales Metropolitan and Regional areas.
 - Providing on-site environmental management advice and technical expertise to various clients undertaking major infrastructure and construction projects such as road, rail, bridge, electrical transmission, pipeline, mining & quarry operations, residential developments, commercial and industrial facilities.
 - Preliminary site assessments for constraints and opportunities.
 - Conducting detailed constructability and operational design reviews for major projects.
 - Devising and drafting Erosion and Sediment Control Plans (ESCP) and Soil and Water Management Plans (SWMP) for projects described above.
 - Researching, formulating, and reviewing Environmental Management Plans (EMP), and supervising the subsequent implementation of plans.
 - Providing advice, expertise, and assistance for the specification, design and placement of soil and water management control.;
 - Undertaking 'Blue Book' soil loss assessments, detailed sediment basin design and associated control structure.;
 - Undertaking environmental inspections and subsequent reporting.
 - Assisting and providing technical guidance to legal practitioners in litigation preparation and expert witness.
 - Preparing, presenting, and participating in environmental awareness workshops and seminars.
 - Drafting, revising, and updating internal management documents and systems involving OH&S and risk management. (i.e., Safe Work Method Statements).
 - Planning and management of Project rehabilitation and revegetation.
 - Assistance and advice for materials selection and site environmental logistics
 - Advice and expertise to control works in riparian areas or in close proximity to sensitive receivers.
 - Preliminary site contamination & Pre/Post Land Condition Assessments

Experience Please see Page 6 - Curriculum Vitae Annexure for Project Consulting History by Description

Curriculum Vitae for Andrew Littlewood

Employment history (Continued)

Organisation	LAKE MACQUARIE CITY COUNCIL - 2000 to 2007
Position	Erosion and Sediment Control Officer
Responsibilities	<ul style="list-style-type: none">• Undertaking inspections of development sites (residential, commercial, and industrial), rural, and unimproved lands to ensure compliance with Councils Erosion and Sediment Control Policy (E&SC Policy), Development Control Plan (DCP) and Conditions of Consent. The inspections encompassed erosion and sediment control, filling and excavation, soils and quarry product storage, vehicle access, landscaping, or other soil disturbance.• Investigating allegations of non-compliance with Councils E&SC Policy, DCP or Conditions of Consent in relation to erosion and sediment control.• Conducting interviews and gathering evidence to issue enforceable notices and penalty infringement notices under the Protection of the Environment Act 1997 (POEO Act) and Local Government Act 1993.• Conducting regular structured audits of developments to ensure compliance and providing a summary audit report for Council's Management Plan.• Assessing ESCP and SWMP for Development Applications and providing comments, proposing amendments, and reviewing work methods, where appropriate.• Preparing detailed reports and internal correspondence to external Government bodies, Councillors, and staff in relation to activities and compliance.• Drafting and preparing documentation on erosion and sediment control activities and initiatives for inclusion in Councils Annual State of The Environment Report.• Initiating and participating in meetings to mediate between opposed parties (ie. Developers and Community groups) to resolve conflict or avoid/minimise litigation.• Representing Council at meetings, seminars, or other forums to communicate Council's policies and intentions.
Experience	<ul style="list-style-type: none">• Applied focussed and committed approach to implement a successful compliance campaign, mitigating erosion and sediment control impacts from developments within the Lake Macquarie catchments. In conjunction with the rehabilitation measures undertaken by the Lake Macquarie Catchment Co-ordinator, over the period from 2000-2009, the program yielded a 95% improvement in the Lake Macquarie water clarity and a 23% increase of seagrass coverage (an increase of 2.4 million m²). (Source: Lake Macquarie Improvement Project – Final Annual Report 2008-2009)• Implemented a structured compliance program for improving residential and commercial erosion and sediment control. The program achieved an improvement in the E&SC policy compliance rates assessed as less than 10% at the outset in 2000, increasing to be consistently above a 75% compliance rate by 2007.

Curriculum Vitae for Andrew Littlewood

Employment history (Continued)

- Experience
- Worked autonomously in the implementation of erosion and sediment control management and compliance on large/complex developments including liaison with proponents, government agencies, and community groups.
 - In conjunction with Council's Environmental Auditor, participated in internal workshops and audits of Council's assessment procedures in relation to erosion and sediment control, leading to process reforms and improvements.
 - Undertook a comprehensive review of Councils existing 'stand alone' E&SC Policy and drafted the relevant policy sections encompassing erosion and sediment control management for the replacement policy, LMCC Development Control Plan 2 - 2003.
 - Initiated and participated in the process to update and expand LMCC's erosion and sediment control website - 2003 & 2006.
 - Key council officer to facilitate LHCCREMS audit of lower Hunter Councils in regard to erosion and sediment control compliance and education activities - 2006.
 - Key contributor in Council's team for Lower Hunter and Central Coast Regional Environmental Management Strategy's (LHCCREMS) focussed on innovative urban water cycle practices - 2001.
 - Key facilitator for LMCC involvement with EPA review of provisions of the POEO Act in relation to erosion and sediment control compliance - 2003.
 - Reviewed and updated internal procedures for the issue of enforceable orders/notices under the Integrated Management System - 2006.
 - Conducted hazard assessment and risk management for operational practices as part of the implementation of the Integrated Management System to AS/NZS 4801 and ISO 9001.

Organisation OFFICE OF THE SHERIFF OF NSW - ATTORNEY GENERAL'S DEPT - 1997 to 2000

Position Sheriff's Officer

Company HUNTER GROUP INVESTIGATIONS PTY. LTD. - 1996 to 1997

Position Investigations Manager

Company LICENSED PRIVATE ENQUIRY AND COMMERCIAL AGENT - 1993 to 1996

Position Self - employed and licensed sole trader

Company NEWCASTLE HUNTER AND NORTHERN INVESTIGATIONS PTY. LTD. - 1991 to 1993

Position Investigations Manager

Company MCDONALD JOHNSON & O'NEILL - SOLICITORS - 1988 to 1990

Position Legal Clerk / Student - at - Law

Referees

Mr Simon Williams - Ph: 0434 095 001
Environment Manager, Engineering
CPB Contractors
177 Pacific Highway
NORTH SYDNEY NSW 2060

Ms. Jacqueline McKenzie – 0411 033 929
Environmental Manager
Downer Group
39 Delhi Road
NORTH RYDE NSW 2113

Mr Steve Dalley - Ph: 0411 258 622
Project & Contracts Manager, Freight & Regional Hunter
NSW Roads and Maritime Service
Level 7, 266 King Street
NEWCASTLE NSW 2300

Mr Jason Gorton - Ph: 0429 844 097
Divisional Manager HSEQT
Daracon Group
20 Kullara Close
Beresfield NSW 2322

Mr Reece Palmer – 0459 226 198
Regional Manager
Ditchfield Contracting
Unit 8 / 12 Channel Road,
Mayfield West NSW 2304

Curriculum Vitae Annexure for Project Consulting History by Description

Experience – Motorways, Roads, and Bridges

Principal Project Soil Conservationist – Motorways & Main Roads

- M1 Pacific Motorway extension to Raymond Terrace – Black Hill to Tomago - 2023
- Hexham Straight Widening – Hexham - 2023
- M1 Pacific Motorway extension to Raymond Terrace – Heatherbrae Bypass - 2023
- Mulgoa Road Upgrade – Penrith -2023
- Ocean Drive Duplication – Port Macquarie - 2022
- Nelson Bay Road Upgrade – Bobs Farm, Section 1 - 2021
- Memorial Drive Upgrade – Kellyville - 2020
- Golden Highway Upgrades – Winery Hill & Ogilvies Hill - 2019
- Pacific Highway Upgrade – Lisarow to Ourimbah Stage 3B - 2019
- Oxley Highway – Gunnedah 2nd Rail Overbridge - 2018
- Princes Hwy Upgrade – Berry to Bomaderry 2018
- Scone Bypass - New England Highway - 2018
- M1 Widening - Tuggerah to Doyalson – 2017
- The Northern Road & Bringelly Road Upgrade – Stage 2 - 2017
- Schofields Road Upgrade – Stage 3 - 2016
- Glendale Transport Interchange - 2015
- Great Western Highway – Mount Victoria Safety Upgrade – 2015
- Old Wallgrove Road Upgrade - 2014
- Pacific Highway Upgrade – Kundabung to Kempsey - 2014
- Schofields Road Upgrade – Stage 2 - 2014
- M5 West Motorway Widening – 2013
- New England Highway Upgrade, Belford to Golden Hwy - 2013
- Newcastle Inner City Bypass - Shortland to Sandgate – 2012
- Camden Valley Way Upgrade – Narellan – 2011
- Central Coast Hwy Upgrades Stage 1 & 2 – 2010/2011
- Pacific Highway Upgrade - Bulahdelah By-Pass Main Works – 2010
- Alfords Point Road Upgrade - 2010
- Avoca Drive Upgrade – 2009
- New England Highway Upgrade, Sunnyside Re-Alignment (Armidale) – 2009
- F3 Motorway Widening - Cowan to Berowra – 2009
- Hunter River Third Crossing - 2009
- Pacific Hwy Upgrade - Ourimbah and Tuggerah Straight Upgrades – 2008
- Pacific Hwy Upgrade - Coopernook to Herons Creek Alliance – 2008
- Pacific Hwy Upgrade - Karuah to Bulahdelah (Stages 2 & 3) – 2008

Major Road Projects - Planning and Development

- Newcastle Inner City Bypass (Detailed Design review) – Rankin Park to Jesmond – 2020
- Maitland Bay Drive Intersection Upgrade – Ettalong - 2020
- Beckers Bridge Replacement – Glendon Brook – 2018
- Brisbane Water Drive & Scenic Drive, Kincumber - 2018
- 'Circuit Italia' Motorsports Complex – Raymond Terrace - 2017
- M1 Widening Projects- Kariong to Somersby & Tuggerah to Doyalson – 2016
- Newcastle Inner City Bypass (Concept Design) – Rankin Park to Jesmond – 2016

Experience – Motorways, Roads, and Bridges

Major Road Projects - Planning and Development (Continued)

- Pacific Highway Upgrade – Failford Road to Tritton Road - 2015
- Windsor Bridge Replacement - 2013
- Sparks Rd Upgrade – M1 to Pacific Hwy – 2013
- Pacific Highway and Wyong Road Upgrade - 2012
- Hexham Roads Maintenance Facility (rail) – 2012/2015
- Bulahdelah By-Pass Early Works – 2010
- Maitland to Minimbah Third Track – 2010
- Greta Train Support Facility – 2010
- Aberdeen Bridge Replacement – 2009

Principal Project Soil Conservationist – Secondary Roads, Upgrades & Bridges

- Raymond Terrace Road & Government Road Intersection Upgrade – Thornton - 2022
- Macquarie Road, Myall Road and Munibung Road upgrade – Cardiff - 2022
- Pacific Highway - Northcott Drive & Kahibah Rd Intersection Upgrade – Highfields - 2021
- Sydney Pinch Point Program – King Georges Road, Wileys Park and Georges River Road, Ashfield -2020.
- Cessnock Road Upgrade – Gillieston Heights (Testers Hollow) - 2020
- Oakdale West Estate, Erskine Park – Western North-South Link Road - 2020
- Newcastle Inner City Bypass – Rankin Park to Jesmond – Jesmond Pedestrian Bridge - 2020
- New England Highway Upgrade – Wyndella Intersection - 2019
- Nelson Bay Road – Fern Bay Seaside Village Intersection - 2019
- Elderslie Bridge Upgrade - 2019
- Monkerai Bridge Replacement - 2019
- Central Coast Highway – Racecourse Road Intersection Upgrade - 2016
- Main Road 220 Freemans Drive - Brunkerville Upgrade Stage 3 – 2015
- Tourle Street Bridge Duplication (early Works) – 2015
- Old Wallgrove Road Upgrade – 2015
- Central Coast Highway - West Gosford Intersection Upgrade – 2013
- Fitzgerald Bridge Replacement, Aberdeen – 2012
- M1 Motorway Interchange and Wyong Road Upgrade – 2012
- Central Coast Highway - Kariong Upgrade Project – 2011
- Thornton Rail Bridge Replacement – 2011
- Warren Road, Warnervale – 2011
- Central Coast Highway - Kariong Pedestrian Underpass & Intersection – 2011
- Warnervale Link Road – 2010
- F3 Motorway - Mooney Mooney Rest Area Upgrade – 2009
- Tourle Street Bridge Replacement – 2008
- Weakleys Drive Interchange – 2008
- Dane Drive Upgrade, Gosford – 2008

Curriculum Vitae Annexure for Project Consulting History by Description

Experience – Motorways, Roads, and Bridges

Project Support – Secondary Roads, Upgrades & Bridges

- Western Distributor Smart Motorway – Sydney CBD West - 2023
- Pacific Highway Upgrade – Lisarow to Ourimbah Stage 3A – 2016
- Pacific Highway and Wyong Road Upgrade – Tuggerah - 2015
- WestConnex M4 Widening Project – 2015
- Maitland Transport Interchange Upgrade - 2015
- Glendale Transport Interchange – 2015
- Pacific Highway Upgrade – Oxley Highway to Kundabung – 2015
- Pacific Highway Upgrade - Woolgoolga to Halfway Creek – 2015
- WestConnex Stage 1B M4 East – 2014
- WestConnex Stage 1A M4 East – 2014
- Mt Kiera Road (Wollongong) Stability Works – 2013
- Pacific Highway Upgrade - Nambucca to Urunga – 2013
- Hunter Expressway (Eastern Section) – 2010

Experience – Rail Projects

Principal Project Soil Conservationist – Rail

- Gosford Passing Loops – 2013
- Hunter Coal Road Bridges - 2013
- Southern Sydney Freight Line – 2011
- Maitland to Minimbah Third Track, Stage 2 - 2011
- North Coast Rail Curve Easing Project – 2011
- Kingsgrove to Revesby Quadruplication – 2010
- Bullock Island Maintenance Facility Upgrade – 2011
- Greta Train Support Facility – 2011
- Yeoval Rail Bridge Demolition – 2011
- Eumungerie Rail Bridge Replacement – 2011
- Port Botany Signalling Upgrade – 2010
- Aberdeen Track Reconditioning – 2010
- Minimbah Bank Third Track, Stage 1 – 2009
- Southern Sydney Freight Line – 2009
- Kerewong Signalling Upgrade, North Coast Rail – 2009
- Ulan Rail Line, Level Crossing Upgrades – 2009
- Loadstone Rail Upgrade – 2009
- Kilbride and Kerewong Crossing Loop Projects, North Coast Rail - 2009
- Newdell Junction Crossing Loop Project, Hunter Valley Rail - 2009
- Boggabri Crossing Loop Project, North West Rail – 2009
- Mindaribba Crossing Loop Project, North Coast Rail – 2009
- Berala Rail Bridge Replacement – 2009
- Gunidgera Creek Bridge Replacement – 2008

Curriculum Vitae Annexure for Project Consulting History by Description

Experience – Rail Projects

Project Support – Rail

- Sydney Metro Northwest (formerly North-West Rail Link) – 2015
- Concord West Rail Station Upgrade – 2013
- Wallis Creek Rail Bridge – 2013
- Kooragang Coal Road Rail Bridge & Kooragang Provisioning Facility Demolition – 2013
- Coggan Creek Track Reconditioning – 2012
- Hexham Roads Rail Maintenance Facility – 2012
- Farley & Allandale Rail Upgrades – 2008
- Pitnacree Rail Bridge – 2008

Major Rail Projects - Planning and Development

- ARTC Inland Rail – Narrabri to Northstar - 2020

Experience – Other Projects

Easements, pipelines & infrastructure

- Eraring Battery Energy Storage System – 2023 – 17ha battery storage development
- Newcastle Airport Capacity Enhancement Terminal – Williamtown - 2023
- Oakdale East Development - Horsley Park – 56ha quarry remediation and commercial development - 2023
- Moomba to Sydney Pipeline – East Coast Grid Expansion: Round Hill (via White Cliffs) Compressor Station - 2022
- Kooragang Eastern Ponds Remediation - 2022
- Moomba to Sydney Pipeline – East Coast Grid Expansion: Condobolin Compressor Station – 2021
- Kooragang Island Waste Emplacement Facility – 2020
- Newcastle BHP Intertrade Precinct Development - 2017
- Crookwell 2 Wind Farm – 2017 & 2018
- North West Growth Centre Project – Plants & pipelines (Sydney Water) - 2015
- Barnard Transmission Easement Upgrade – 2014
- Sydney West to Holroyd 330kV Transmission Upgrade – 2012
- Mayfield West Water Treatment Plant & Transfer Pipeline: Kooragang Industrial Water Scheme – 2012
- Vineyard and Wallerawang 330kV/132kV Sub-Stations – 2010
- Tomago 330kV/132kV Sub-Station – 2009
- Western Sydney Replacement Flows Project – 2009
- Bulahdelah By-Pass - Transgrid easement – 2009
- Colongra Lateral Pipeline Project – 2008

Mines, Quarries & Waste Facilities

- Astra Street Landfill Remediation – Shortland - 2022
- Hornsby Quarry Rehabilitation - 2021
- Speers Point Quarry – Munibung Residential Development - 2020
- Mach Energy - Mount Pleasant Rail Loop - 2020
- Woy Woy Waste Management Facility - 2019
- Awaba Waste Management Facility – 2017 & 2018
- Muswellbrook Quarry Rehabilitation - 2016
- Mockingbird (Kempsey) Quarry Rehabilitation - 2015
- Stockrington Quarry Rehabilitation - 2015
- Buttai Quarry Benches Rehabilitation – 2010
- Mangoola Coal Project – 2010
- Integra Coal, Drainage Upgrade – 2009

Experience – Land Condition Assessments

Preliminary site contamination & Transport for NSW Pre & Post Land Condition Assessments

- M1 Pacific Motorway extension to Raymond Terrace – Heatherbrae Bypass (Pre-Construction) 2023
- Mulgoa Road Upgrade – Penrith (Pre-Construction) 2023
- Raymond Terrace Road & Government Road Intersection Upgrade (Pre-Construction) – Thornton - 2022
- Ocean Drive Duplication – Port Macquarie (Pre-Construction) - 2022
- Shoalhaven Starches Gas Pipeline Project – Merroo Meadow (Pre-Construction) - 2022
- Queens Bridge Repainting, Queanbeyan - 2022 (Pre & Post Construction)
- Macquarie Road, Myall Road, and Munibung Road Cardiff upgrade (Pre & Post Construction)- 2022
- Karuah River Bridge Upgrade – 2022 (Pre-Construction)
- Princes Hwy Upgrade – Berry to Bomaderry - 2022 (Post-Construction)
- Denman Road & Thomas Mitchell Drive Intersection Upgrade, Muswellbrook – 2021 (Pre-Construction)
- Nelson Bay Road – Bobs Farm to Salt Ash – 2021 & 2023 (Pre-Construction & Post Construction)
- Brisbane Water Drive & Scenic Drive, Kincumber - 2021 (Post-Construction)
- Hinton Bridge Repainting, Hinton (TfNSW) - 2021 (Pre-Construction)
- Dawson River Bridge Upgrade, Taree (TfNSW) - 2021 (Pre & Post-Construction)
- Sydney Pinch Point Program – King Georges Road and Georges River Road – 2021 (Pre & Post Construction)
- Monkerai Bridge Replacement, Monkerai (TfNSW) – 2020 (Post-Construction)
- Memorial Drive Upgrade – Kellyville – 2020 (Pre-Construction)
- Cessnock Road Upgrade – Gillieston Heights (Testers Hollow) 2020 (Pre-Construction)
- Maitland Bay Drive Intersection Upgrade – Ettalong (TfNSW) – 2020 & 2021(Pre & Post Construction)
- Newcastle Inner City Bypass – Jesmond Pedestrian Bridge – 2019 & 2021 (Pre & Post Construction)
- New England Highway Upgrade – Wyndella Intersection – 2019 & 2020 (Pre & Post Construction)
- Golden Highway Upgrades – Winery Hill & Ogilvies Hill – 2019 & 2020 (Pre & Post Construction)
- Pacific Highway Upgrade – Ourimbah to Lisarow Stage 3B – 2018 & 2023 (Pre-Construction& Post)
- Oxley Highway – Gunnedah 2nd Rail Overbridge – 2018 & 2021 (Pre & Post Construction)
- Scone Bypass - New England Highway – 2018 & 2020 (Pre & Post Construction)
- Mount Thorley Warkworth - Third Crossing of Putty Road – 2016 (Pre-Construction)
- ARTC Old East Maitland Depot, East Maitland - Potential Contamination & Environmental Assessment – 2016